

- GSM /GPRS packet transmission and SMS messaging
- Integral GSM 850/900/1800/1900 modem with autonomic GPRS network logon system
- 6 binary/counter inputs with support for potential free contacts (e.g. for connecting water meters pulse outputs)
- 3 analog 0-5 VDC inputs with configurable alarm thresholds and hysteresis
- 2 controlling outputs
- Keyed 0-5 VDC power supply for external analog converters
- Vibration sensor (detection of intrusion)
- Optional flooding sensor
- Optional built-in pressure transducer
- Intelligent data logger (4 MB Flash memory - max. 10 000 records)
- Configurable events and schedules initiating measurements and data transmission
- Real Time Clock
- 7-30 VDC power supply (alkaline or lithium batteries, rechargeable batteries, solar panel, DC power supply)
- Intelligent power management
- USB port (IP68) for local configuration
- IP68 enclosure and connectors, electronics covered by protective gel
- Measure of energy used
- Optional GPS receiver



- SMB IP68 antenna connector
- -20°... +55°C operating temperature
- User friendly communication and configuration applications
- Support for GPRS based remote management and firmware update

MT-723 module is a data logging and transmitting device with the highest degree of protection against harsh external environment. Like other modules from MT family MT-723 module is a cutting edge design characterized by technological advancement, innovative solutions, ease of configuration and integration with data gathering and processing systems. Module has possibility of initiating data transmission (event-driven or scheduled) what helps to minimize the transmission costs and energy consumption, therefore increasing battery life. However it is possible to set up device to stay online permanently or for desired time thus allowing to poll both current, logged or both types of data asynchronously from module. Robust, compact design enclosed in a polycarbonate housing with IP68 protection module allows installation and usage of module in places with harsh environment and without power supply (such as water supply network measuring chambers). The module can be powered from alkaline or lithium battery packs, batteries, solar panels as well as from stationary sources of power. Voltage level of power source is constantly monitored and transmitted together with measurement data. In the case of disconnection of an external power supply internal lithium battery provides power essential for counting pulses on inputs I1...I6, sustains the RTC clock and triggers power loss alarm. MT-723 module is equipped with 6 binary/

counter inputs (supporting potential free contacts used e.g. as pulse outputs of water meters) and three analog inputs for measuring parameters such as pressure, temperature, water level, etc. Keyed voltage source for powering analog sensors which provides power only for a short time needed for measurement and outputs that can be used for controlling external power source powering analog sensors are solutions which, in conjunction with the deactivation of GSM/GPRS modem when there is no data transmission, ensure an extremely low power consumption. Measurement data is stamped with precise time and can be recorded in nonvolatile Flash memory. In addition to measuring functions module can also report states of emergency such as mechanical shock, flooding, unauthorized opening of the chamber, lack of flow, exceeding specified level of flow, pressure, water level, temperature, humidity, etc. Resources and functionality of the MT-723 module can be optimized for specific applications thanks to the many available options (module flooding sensor, pressure transmitter, GPS receiver). The module is supplied with userfriendly configuration environment and communication driver providing OPC, ODBC and CSV interfaces for data reception and the software for remote management via GPRS. User can manage modules from remote via GPRS. Remote management includes firmware updates.



6DI/2DO

3AI



MT-723

General

Dimensions (length x width x height)	80x140x65 mm
Weight	600 g
Mounting type	4 holes
Operating temperature	-20 ... +55°C
Protection class	IP68

GSM/GPRS Modem

Modem type	SIERRA WIRELESS
GSM	Quad Band (850/900/1800/1900)
Frequency range:	
GSM 850	Transmitter: 824MHz – 849 MHz Receiver: 869 MHz – 894 MHz
EGSM 900	Transmitter: 880 MHz – 915 MHz Receiver: 925 MHz – 960 MHz
DCS 1800	Transmitter: 1710 MHz – 1785 MHz Receiver: 1805 MHz – 1880 MHz
PCS 1900	Transmitter: 1850 MHz – 1910 MHz Receiver: 1930 MHz – 1990 MHz
Transmitter peak power GSM850/EGSM900	33 dBm (2W) – class 4 station
Transmitter peak power DCS1800/PCS1900	30 dBm (1W) – class 1 station
Modulation	0,3 GMSK
Channel spacing	200 kHz
Antenna	50Ω

Power

Power voltage range	7 – 30 VDC
Medium current in sleep mode (for 12 V)	<250 μA
Medium current when transmitting data (for 12 V)	25 mA
Maximum peak current when transmitting data (for 12 V)	500 mA

Analog inputs AN1...AN3 (voltage, differential)

Input signal range	0 ... 5,0 V
Input resistance	>600 kΩ typ.
Resolution	12 bits
Accuracy in full operating temperature range	± 0,3 %
Accuracy in 25°C	± 0,1 %

Binary/counter inputs I1...I6

Contact polarization	3 V
Counting frequency for counter inputs	250 Hz max.
Minimal pulse length for counter inputs	2 ms
Minimal pulse length for binary inputs	0,1 s

NMOS outputs Q1, Q2

Maximum voltage	30 V
Maximum current	250 mA
Switch off current	< 50 μA
Resistance	1Ω

Configurable voltage output

Voltage range	0 ... 5,0 V
Resolution	0,1 V
Accuracy	2 %
Maximum current	50 mA

Logger

Memory type	FLASH
Memory size	4 MB (10 000 records)
Minimum recording interval	1 s

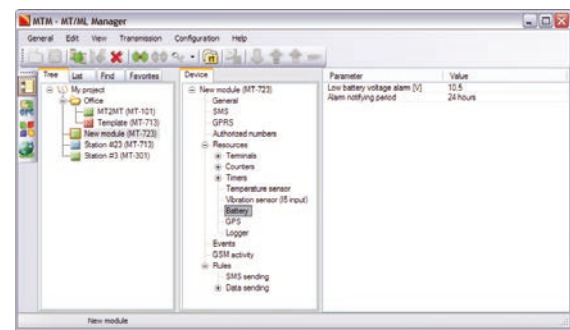
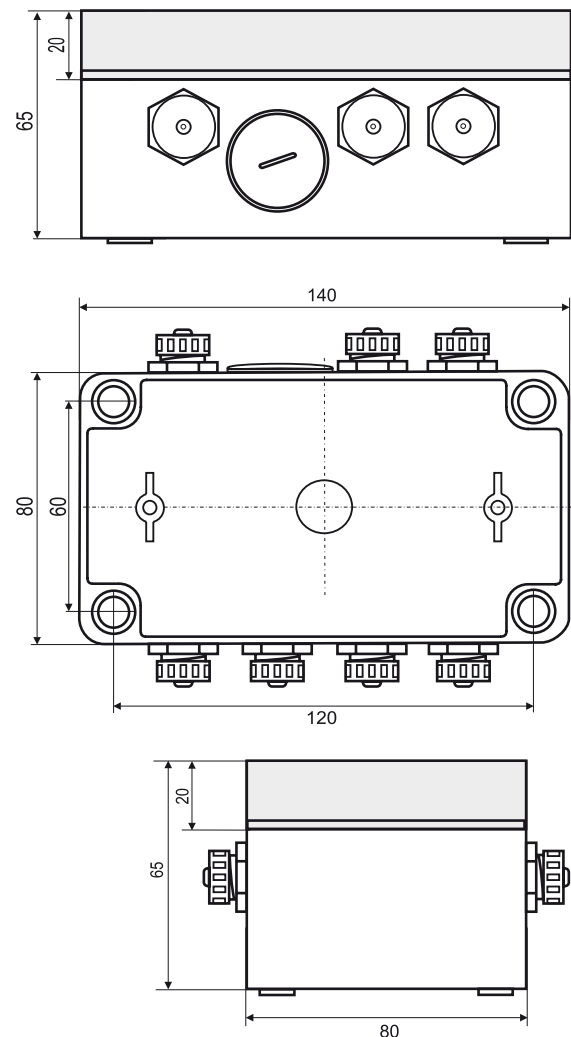
Configuration environment**Drawings and dimensions (all dimensions in millimeters)****Supplementary information:**

inventia

INVENTIA Ltd.

ul. Kulczyńskiego 14, 02-777 Warsaw, POLAND

tel.: +48 22 545-32-00, 545-32-01

fax: +48 22 643-14-21

inventia@inventia.pl, www.inventia.pl



INVENTIA complies with ISO 9001:2008 certified Quality Management System!
This project is co-financed by EUROPEAN UNION
from the European Regional Development Fund resources.