

# *AcuDC 240 Series*

## DC Power and Energy Meters



- DC Energy Management Systems
- Power Distribution for Telecommunication Room
- Solar Photovoltaic Systems
- Wind Power Generation
- DC Excitation System
- Industrial DC Control Systems
- Metallurgy and Electroanalysis Industries
- EV Charging Monitoring
- Data Center
- Cellular Tower Energy Monitoring



ISO9001 Certified

**ACCUENERGY**

# AcuDC 240 Series DC Power Meter



## INTRODUCTION

AcuDC 240 series power meter can be used for monitoring and controlling in DC systems. These meters can measure a wide range of parameters such as voltage, current, power and energy. It supports bi-directional current measurement, digital inputs for switch monitoring and relay outputs for remote controlling as well as an over-range alarming feature for voltage and current. Large signals, such as voltage and current can be converted to smaller signal using analog output. All data in the meter is accessible via RS485 using open Modbus RTU protocol. The large 3 line LCD display also provides easy to read real-time data directly on the meter front.

## APPLICATIONS

- DC Energy Management Systems
- Power Distribution for Telecommunication Room
- Solar Photovoltaic Systems
- Industrial DC Control Systems
- Metallurgy and Electroplating Industries
- Wind Power Generation
- DC Excitation Systems
- Light Rail Transit Systems
- EV Charging Monitoring
- Data Center
- Cellular Tower Energy Monitoring

## FEATURES

- DC power system metering
- Monitor and control power switches
- Alarming and analog output
- Standard 72x72mm, allows for drawer type panel installation
- Three line high-definition LCD display
- Accessible with SCADA, PLC systems
- Easy installation, simple wiring
- Data Logging: Offers 3 assignable historical logs where the all of the metering parameters can be recorded. The onboard memory is up to 4 MB and each log size is adjustable.



## SPECIFICATIONS

Function		AcuDC 241	AcuDC 242	AcuDC 243
METERING	Voltage	V	●	●
	Current	I		●
	Power	P		●
	Energy	E		●
	Ampere-hour	Ah		●
I/O	2DI+2AO	Support DI count	○	○
	2DI+2RO		○	○
	2DI+2DO		○	○
	2DI+ ±15Vdc		○	○
DATALOGGING	All metering parameters can be recorded (Voltage, Current, Power, Energy, Ampere-hour, DI Count); Interval 1 minute; Can record 4 months			○
COMMUNICATION	RS485 , Modbus RTU		○	○
DISPLAY	LCD		●	●
DIMENSIONS	72×72×64.5mm (Cutout: 68x68 mm) / 2.835 x 2.835 x 2.539 inch (Cutout: 2.677 x 2.677 inch)			

Note: ● Standard; ○ Optional Blank: Not Available

# TYPICAL WIRING

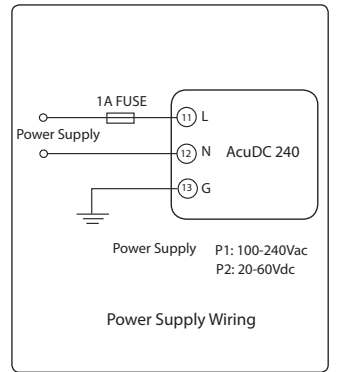
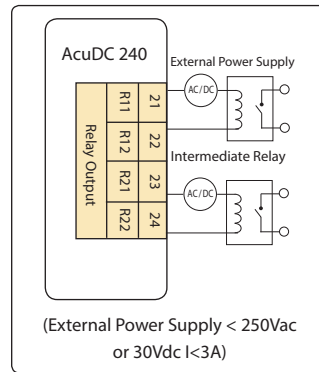
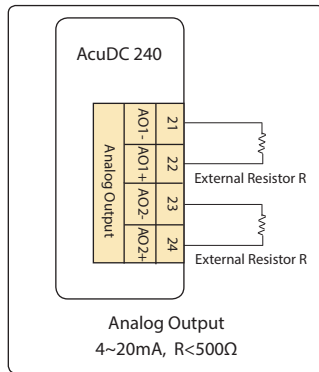
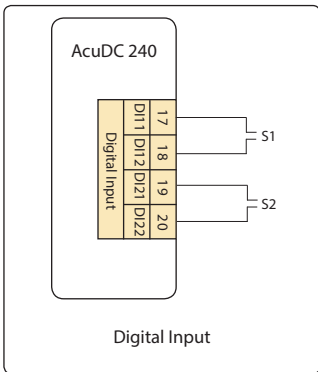
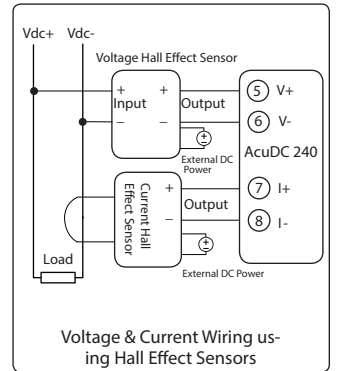
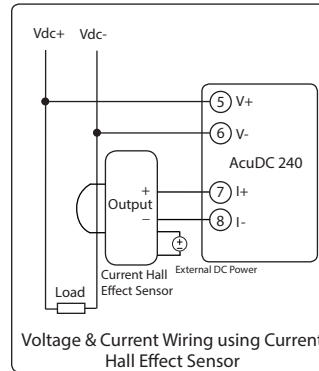
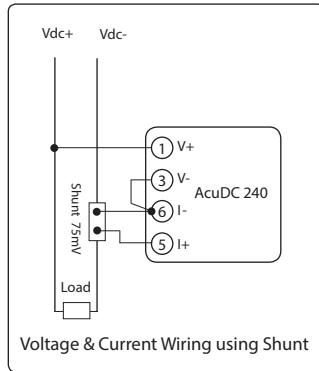
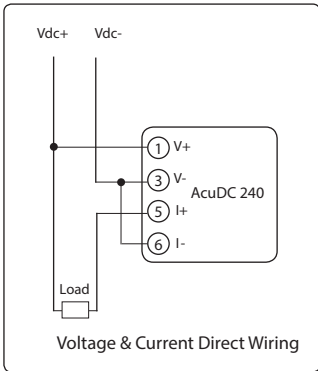
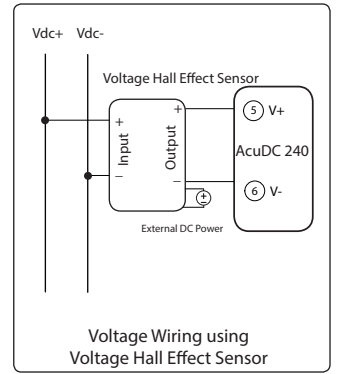
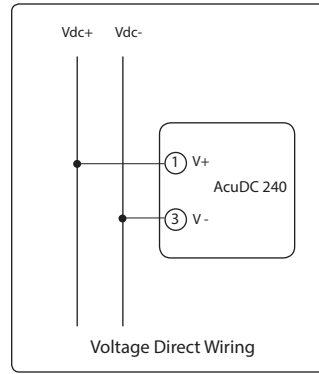
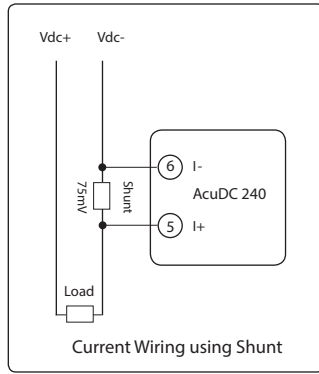
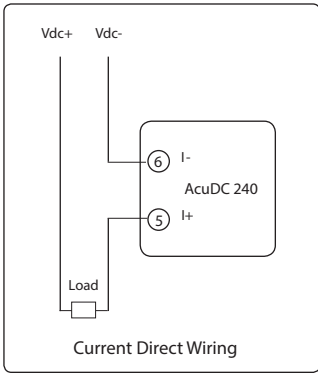

# DIMENSIONS

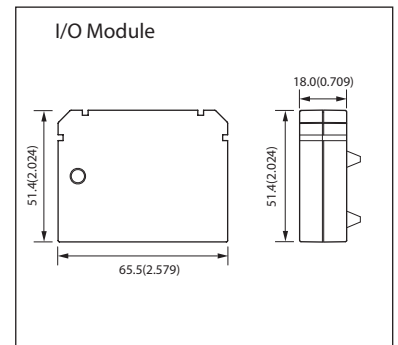
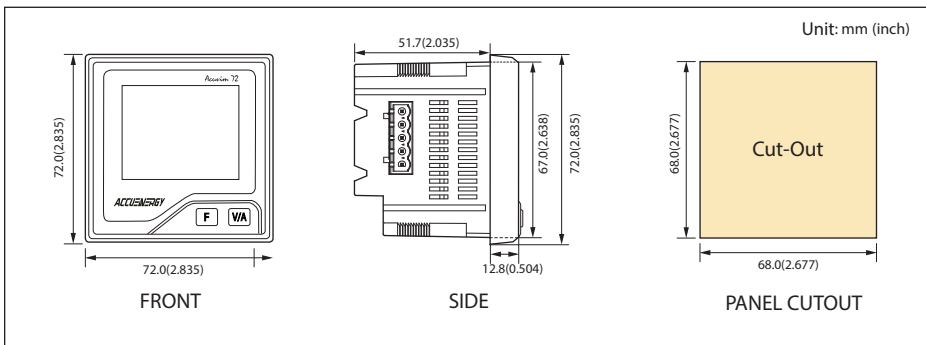

## TECHNICAL SPECIFICATIONS

Parameter	Accuracy	Resolution	Range
Voltage	0.2%	0.001V	0~1200V
Current	0.2%	0.001A	0~±50000A
Power	0.5%	0.001kW	0~±60000kW
Energy	0.5%	0.01kWh	0~9999999.99kWh
Drift with Temperature	<100ppm/°C		
Stability	0.5%/year		

Voltage	
Input Range	
Voltage	Direct Input 0~1000V; Via Hall Effect Sensor 0~1200V
Input Impedance	2MΩ
Load	<0.6W
Accuracy	0.2%

Current	
Input Range	0~±10A (Direct Input, pick up current 0.01A) 0~±50000A (Via Shunt or Hall Effect Sensor, programmable range)
Shunt	50~100mV (programmable)
Hall Effect Sensor	0~±5V/0~±4V, 4~20mA/12mA±8mA
Power Consumption	2W (Max)
Accuracy	0.2%

Digital Input	
Type	Dry Contact
Isolation Voltage	2500Vdc

Environment	
Operation Temperature	-25°C ~ +70°C
Storage Temperature	-40°C ~ +85°C
Humidity	5%~95% Non-condensing

Output	
Relay Output (RO)	
Type	Mechanical contact, Form A
Max Load Voltage	250Vac/30Vdc
Max Load Current	3A
On Resistance	100mΩ (Max)
Isolation Voltage	4000Vdc
Mechanical Life	5 × 10 <sup>6</sup> times

Digital Output (Photo-Mos)	
Load Voltage Range	0~250Vac/dc
Load Current	100mA (Max)
Max Output Frequency	25Hz, 50% duty cycle
Isolation Voltage	2500Vdc

Analog Output (AO)	
Range	4-20mA/0~20mA; 0~5V/1-5V
Accuracy	0.5%
Load Capacity	Current type, max load resistance: 750 Ohm Voltage type, max load current: 20 mA

Communication	
Type	RS485, half duplex, Optical Isolated
Protocol	Modbus-RTU
Baud rate	1200~38400bps
Isolation Voltage	2500Vdc

Power Supply	
Input	(P1) 100-240Vac, 50/60Hz, 100-300Vdc (P2) 20-60Vdc
Consumption	3W (typical value)

Installation	
72×72 mm	Panel mounted

## ORDERING INFORMATION

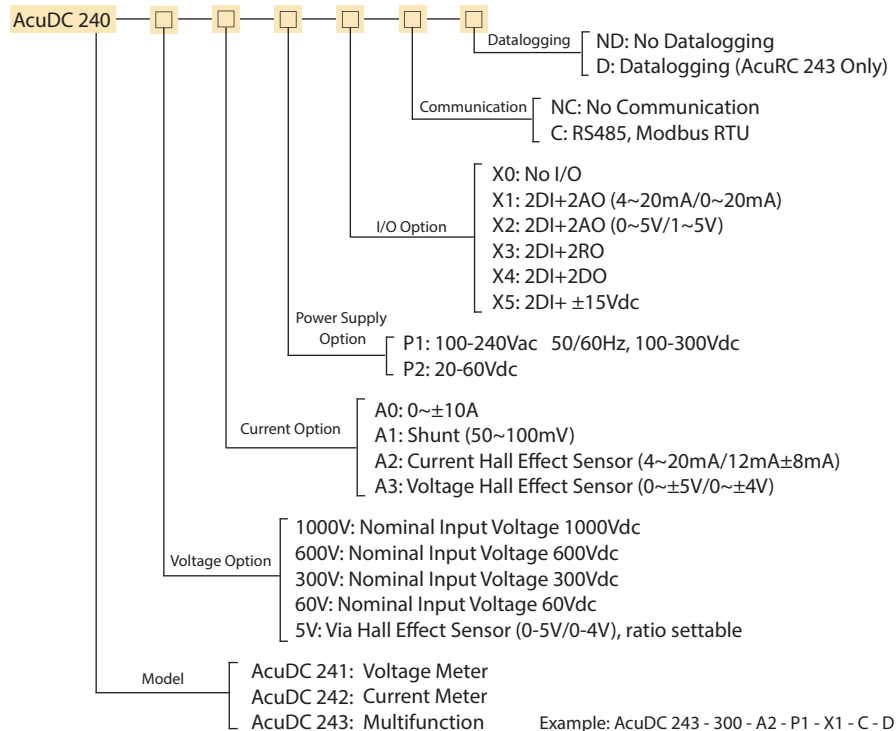

### VOLTAGE HALL EFFECT SENSOR ORDERING INFORMATION (0~5V output)

Special order

Please contact your local Accuenergy Representative for further details

### CURRENT HALL EFFECT SENSOR ORDERING INFORMATION (4~20 mA output)

Special order

Please contact your local Accuenergy Representative for further details

Note:

1. When the input voltage is above 1000V, or the system design requires an isolation sensor, the voltage input can be selected as Via Hall Effect Sensor (0~5 V). The Voltage Hall Effect Sensor output range requires 0~5 V.



**Accuenergy Corp**

Los Angeles-Toronto-Beijing

North American Toll Free: 1-877-721-8908

Web: www.accuenergy.com

Email: marketing@accuenergy.com

Revision Date: Feb., 2014

Document #1504E1103