

Conext™ TL Photovoltaic Grid Tie Inverters

Conext TL 8000 E

Conext TL 10000 E

Conext TL 15000 E

Conext TL 20000 E

Installation and Operation Manual



Conext TL Photovoltaic Grid Tie Inverters

Conext TL 8000 E

Conext TL 10000 E

Conext TL 15000 E

Conext TL 20000 E

Installation and Operation Manual

Copyright © 2013 Schneider Electric. All Rights Reserved.

All trademarks are owned by Schneider Electric Industries SAS or its affiliated companies.

Exclusion for Documentation

Unless specifically agreed to in writing, seller

- (a) makes no warranty as to the accuracy, sufficiency or suitability of any technical or other information provided in its manuals or other documentation;
- (b) assumes no responsibility or liability for losses, damages, costs or expenses, whether special, direct, indirect, consequential or incidental, which might arise out of the use of such information. The use of any such information will be entirely at the user's risk; and
- (c) reminds you that if this manual is in any language other than English, although steps have been taken to maintain the accuracy of the translation, the accuracy cannot be guaranteed. Approved content is contained with the English language version which is posted at www.schneider-electric.com.

Date and Revision

February 2013 Revision B

Part Number

975-0609-01-01

Contact Information

www.schneider-electric.com

For other country details please contact your local Schneider Electric Sales Representative or visit our website at:
<http://www.schneider-electric.com/sites/corporate/en/support/operations/local-operations/local-operations.page>

About This Manual

Purpose

The purpose of this Installation and Operation Manual is to provide explanations and procedures for installing, operating, maintaining, and troubleshooting these inverters:

- Conext TL 8000 E (part number PVSNVC8000)
- Conext TL10000 E (part number PVSNVC10000)
- Conext TL15000 E (part number PVSNVC15000)
- Conext TL 20000 E (part number PVSNVC20000)

Scope

The manual provides safety guidelines, detailed planning and setup information, procedures for installing the inverter, as well as information about operating and troubleshooting the inverter.

Audience

The information in chapters “Introduction” (page 1–1), “Operation” (page 3–1), and “Troubleshooting” (page 4–1) is intended for the owner and operator of the inverter, and does not require any special training or qualifications. The information in chapters “Installation and Configuration” (page 2–1) and “Preventive Maintenance” (page 5–1) is intended for qualified personnel only. Qualified personnel have training, knowledge, and experience in:

- Installing electrical equipment and PV power systems (up to 1000 V).
- Applying all local installation codes.
- Analyzing and eliminating the hazards involved in performing electrical work.
- Selecting and using Personal Protective Equipment (PPE).

Installation, commissioning, troubleshooting, and maintenance of the inverter must be done only by qualified personnel.

Organization

This manual is organized into the following chapters and appendixes.

Chapter 1, “Introduction” contains information about the features and functions of Conext TL 8000 E, Conext TL 10000 E, Conext TL 15000 E and Conext TL 20000 E photovoltaic grid tie inverters.

Chapter 2, “Installation and Configuration” provides information and procedures for installing and configuring the inverter.

Chapter 3, “Operation” contains information on the basic operation of the inverter.

Chapter 4, “Troubleshooting” describes the error messages that might be displayed on the LCD of the inverter and recommended solutions.

Chapter 5, “Preventive Maintenance” contains information and procedures for performing preventive maintenance on the inverter.

Appendix A provides the environmental, electrical, and other specifications for the inverters.

Appendix B describes the information that can be displayed on the LCD of the inverter.

Appendix C describes the voltage and frequency disconnect settings and the reconnect time that the inverter provides for each country selectable from the user interface.

“Information About Your System” can be used to record information about your inverter package.

Conventions Used

This manual uses the following conventions for conveying important safety related information.

DANGER

DANGER indicates an imminently hazardous situation that, if not avoided, will result in death or serious injury.

WARNING

WARNING indicates a potentially hazardous situation that, if not avoided, can result in death or serious injury.

CAUTION

CAUTION indicates a potentially hazardous situation that, if not avoided, can result in moderate or minor injury.

NOTICE

NOTICE indicates important information that you must read carefully.

Product Names

This manual includes information for four products: Conext TL 8000 E, Conext TL 10000 E, Conext TL 15000 E and Conext TL 20000 E photovoltaic grid tie inverters. The following table lists the naming conventions used to differentiate information that only applies to one of the four inverters. For information common to all products, “inverter” is used.

Product Name	Usage
Conext TL 8000 E	Information provided is specific to the 8 kVA Conext photovoltaic grid tie inverter
Conext TL 10000 E	Information provided is specific to the 10 kVA Conext photovoltaic grid tie inverter
Conext TL 15000 E	Information provided is specific to the 15 kVA Conext photovoltaic grid tie inverter
Conext TL 20000 E	Information provided is specific to the 20 kVA Conext photovoltaic grid tie inverter

Abbreviations and Acronyms

Term	Definition/description
AC	Alternating Current
Cap	Capacitive
DC	Direct Current
GND	Ground
Ind	Inductive
I _{sc}	Short circuit current rating of an PV panel under STC. (See STC, below.)
L1	Line 1
L2	Line 2
L3	Line 3
LCD	Liquid Crystal Display
LED	Light Emitting Diode (indicator light)

Term	Definition/description
MPP	Maximum Power Point
MPPT	Maximum Power Point Tracking
N	Neutral
OD	Outer Diameter
PE	Protective Earth (ground)
P _n	Real power nominal
PPE	Personal Protective Equipment
PV	Photovoltaic
Q	Reactive power
RCD	Residual Current Detection
RCMU	Residual Current Monitoring Unit
SELV	Safety Extra Low Voltage
S _n	Apparent power nominal
STC	Standard Test Conditions specific to photovoltaic panels (1000 W/m ² , light spectrum AM 1.5 and 25 °C [77 °F]); panel nameplate ratings are based on STC and may be exceeded under some conditions.
U	Voltage
VAC	Volts AC
VDC	Volts DC
VMPP	Voltage at Maximum Power Point
VOC	Open circuit voltage rating of a PV panel under STC

Related Information

You can find more information about Schneider Electric, as well as its products and services, at www.schneider-electric.com.

Product Recycling



Do not dispose of this product with general household waste!

Electric appliances marked with the symbol shown must be professionally treated to recover, reuse, and recycle materials, in order to reduce negative environmental impact. When the product is no longer usable, the consumer is legally obligated to ensure that is collected separately under the local electronics recycling and treatment scheme.

Important Safety Instructions

READ AND SAVE THESE INSTRUCTIONS - DO NOT DISCARD

This manual contains important safety instructions for Conext TL 8000 E, Conext TL 10000 E, Conext TL 15000 E and Conext TL 20000 E photovoltaic grid tie inverters that must be followed during the installation and maintenance of the inverter. Be sure to read, understand, and save these safety instructions.

⚠ DANGER
HAZARD OF FIRE, ARC FLASH, OR ELECTRIC SHOCK FROM MULTIPLE SOURCES
<ul style="list-style-type: none">• To be installed and serviced only by qualified personnel.• Before servicing, disconnect all sources and wait at least 1 minute.
Failure to follow these instructions will result in death or serious injury.

The term “qualified personnel” is defined on page iii of this manual. Personnel must be equipped with appropriate PPE and follow safe electrical work practices. The inverter is energized from the AC grid and up to four PV circuits. Before servicing the inverter or accessing the communication module, disconnect all sources and wait at least 1 minute to allow internal circuits to discharge. Operating the RID (Remote Inverter Disable) circuit or the switch on the inverter does not remove all power from the inverter. Internal parts and the external wiring remain live unless the PV and AC circuits have been disconnected externally.

⚠ WARNING
LIMITATIONS ON USE
<ul style="list-style-type: none">• Do not use the inverter in connection with life support systems or other medical equipment or devices.• Use the inverter only in grid-interconnected PV systems. The inverter does not support off-grid, stand-alone, power backup function.• Persons with pacemakers must avoid coming in close proximity of this equipment.
Failure to follow these instructions can result in death or serious injury.

▲ WARNING

HAZARD OF ELECTRIC SHOCK, FIRE, AND EQUIPMENT DAMAGE

To prevent unsafe conditions and damage to the inverter, comply with the instructions and the electrical, physical, and environmental installation specifications listed in this manual.

Failure to follow these instructions can result in death or serious injury.

▲ CAUTION

HAZARD OF BURN

The Conext Inverter heat sink could reach temperatures over 158 °F (70 °C) and can cause skin burns if accidentally touched. Make sure the Conext Inverter is located away from traffic areas.

Failure to follow these instructions can result in minor or moderate injury.

NOTICE

HAZARD OF EQUIPMENT DAMAGE

- The inverter packaging box/carton has been provided with a shock watch sticker.
- If the unit is received with the shock watch tripped, check if the inverter is damaged before receiving it from the shipper.
- Do not install or attempt to operate the inverter if it has been dropped or has received more than cosmetic damage during transport or shipping. If the inverter is damaged, or suspected to be damaged, contact Schneider Electric.
- The inverter is designed and certified for full power operation at ambient temperatures up to 40 °C (104 °F). Operation between 40 °C (104 °F) to 60 °C (140 °F) will result in reduced output power.

Failure to follow these instructions can result in damage to equipment.

Contents

Important Safety Instructions - - - - - ix

Introduction

Description of the Conext Grid Tie Solar Inverter - - - - -	1-2
Features - - - - -	1-2
Physical Features - - - - -	1-3
Safety Label - - - - -	1-6
Interface Panel - - - - -	1-8

Installation and Configuration

Installation Overview - - - - -	2-2
Planning - - - - -	2-2
PV Planning - - - - -	2-2
Recommended Protection Devices and Conductor Sizing - - - - -	2-4
PV Wiring Diagrams - - - - -	2-6
AC Grid Connection Planning - - - - -	2-9
Recommended Protection Devices, Conductor Type and Sizing - - - - -	2-9
Environmental Requirements - - - - -	2-10
Choosing the Right Location for Mounting - - - - -	2-10
Unpacking - - - - -	2-12
Verify the Package Contents - - - - -	2-12
Unpack the Inverter - - - - -	2-12
Check the Inverter - - - - -	2-14
Tools Required - - - - -	2-16
Views and Dimensions - - - - -	2-17
Ventilation - - - - -	2-19
Mounting - - - - -	2-20
Correct Mounting Position - - - - -	2-20
Mounting Plate - - - - -	2-22
Dimensions of the Mounting Plate - - - - -	2-22
Correct Position of the Mounting Plate - - - - -	2-23
Fastening the Mounting Plate to the Wall - - - - -	2-25
Mounting the Inverter - - - - -	2-28
Wiring - - - - -	2-29
AC Wiring - - - - -	2-29

Contents

AC Plug Wiring - - - - -	2-29
Maximum AC Cable Length - - - - -	2-30
Connecting the AC Plug - - - - -	2-30
DC Wiring (From PV Array)- - - - -	2-37
DC Wiring Polarity- - - - -	2-37
Connection- - - - -	2-38
Earthing Terminal - - - - -	2-38
Communication Module - - - - -	2-41
Removing the Communication Module - - - - -	2-42
Internal Data Logger - - - - -	2-42
Connecting Cables to the Communication Module - - - - -	2-43
RS485 Connection- - - - -	2-45
RS485 Connection Using the RJ-45 Connectors - - - - -	2-46
RS485 Connection Using the 5-Position Terminal Block - - - - -	2-47
Termination Resistor - - - - -	2-48
RID (Remote Inverter Disable) Input Connection - - - - -	2-49
Dry Contact Output Connection - - - - -	2-50
Remote Monitoring Services - - - - -	2-50
Starting the Conext TL Inverters- - - - -	2-51
Navigating the LCD Menus and Screens - - - - -	2-51
Selecting the Country - - - - -	2-52
Selecting the Language - - - - -	2-54
Menu Structure- - - - -	2-55
Changing the Settings (Settings Menu)- - - - -	2-57
Setting the Date and Time - - - - -	2-57
Coefficient Settings Menu - - - - -	2-57
Install Settings Menu - - - - -	2-58
Insulation Setting- - - - -	2-59
RCMU Setting - - - - -	2-60
DC Injection Setting- - - - -	2-60
Grid System Setting- - - - -	2-61
Grid Setting - - - - -	2-62
Active/Reactive Power Menu - - - - -	2-62
Setting the Active Power Control - - - - -	2-62
Setting the Frequency-Dependent Active Power Control- - - - -	2-63
Setting the Reactive Power Control- - - - -	2-66
Low Voltage Ride Through - - - - -	2-72
For Country setting "Italy"- - - - -	2-75
Italy Selftest Menu - - - - -	2-76

Exiting Technician or Service Mode Level of Security Access-----	2-77
Restoring the Inverter to its Default Settings-----	2-77
FRT settings for PO12.3 (Spain) on display-----	2-78

Operation

Turning the Inverter On-----	3-2
LCD and Control Panel-----	3-2
Navigating the LCD Menus and Screens-----	3-3
Indicator Light-----	3-4
Home Page (E-Today)-----	3-4
Main Menu-----	3-5
Menu Structure-----	3-5
Selecting a Language-----	3-6
Viewing Performance Values-----	3-6
Power Meter-----	3-6
Operation Data-----	3-7
Logs-----	3-7
Viewing Power Generation Logs (“Energy Log”)-----	3-7
Event Log-----	3-8
Inverter Information-----	3-8
Changing the Settings (Settings Menu)-----	3-9
Personal Settings Menu-----	3-9

Troubleshooting

Messages-----	4-2
---------------	-----

Preventive Maintenance

Periodic Maintenance-----	5-2
Semi-Annual Maintenance-----	5-3

Specifications

System Specifications-----	A-2
Environmental Specifications-----	A-2
Electrical Specifications-----	A-3
RCMU-----	A-4
System Information and Communication Specifications-----	A-5
Regulations and Directives-----	A-6
Dimensions-----	A-6
Efficiency Curves-----	A-7

Contents

Descriptions of LCD Information

Description of Information Displayed on the LCD ----- B-2

Country-Specific Settings

Description of Settings Specific to the Selected Country ----- C-2

Information About Your System----- D-1

Index ----- E-1

Figures

Figure 1-1	Typical installation -----	1-2
Figure 1-2	Block diagram Conext TL 8000 E, Conext TL 10000 E, Conext 15000 E and Conext 20000 E models -----	1-4
Figure 1-3	Location of important physical features Conext TL 8000 E and Conext TL 10000 E models -----	1-5
Figure 1-4	Location of important physical features Conext TL 15000 E and 20000 E models -----	1-6
Figure 1-5	Safety label -----	1-6
Figure 1-6	French UTE C 15-712-1 label (required for installations in France only) -----	1-7
Figure 1-7	Bottom of the inverter Conext TL 8000 E and Conext TL 10000 E models -----	1-8
Figure 1-8	Bottom of the inverter Conext TL 15000 E and Conext TL 20000 E models -----	1-9
Figure 2-1	Connection diagram Conext TL 8000 E and Conext TL 10000 E models -----	2-6
Figure 2-2	Connection diagram Conext TL 15000 E and Conext TL 20000 E models -----	2-7
Figure 2-3	External DC disconnect switches-----	2-8
Figure 2-4	AC connection details-----	2-9
Figure 2-5	Lifting the inverter out of the crate Conext TL 8000 E and Conext TL 10000 E models-----	2-13
Figure 2-6	Lifting the inverter out of the crate Conext TL 15000 E and Conext TL 20000 E models-----	2-14
Figure 2-7	Location of nameplate label Conext TL 8000 E and Conext TL 10000 E models -----	2-15
Figure 2-8	Location of nameplate label Conext TL 15000 E and Conext TL 20000 E models -----	2-15
Figure 2-9	Views and dimensions Conext TL 8000 E and Conext TL 10000 E models -----	2-17
Figure 2-10	Views and dimensions Conext 15000 E and Conext TL 20000 E models -----	2-18
Figure 2-11	Airflow Conext TL 8000 E and Conext TL 10000 E models --	2-19
Figure 2-12	Airflow Conext TL 15000 E and Conext TL 20000 E models -	2-20
Figure 2-13	Correct mounting position-----	2-21
Figure 2-14	Incorrect mounting positions-----	2-21

Figures

Figure 2-15	Proper installation distances Conext TL 8000 E, Conext TL10000 E, Conext TL15000 E and Conext TL 20000 E models - - - - -	2-22
Figure 2-16	Mounting plate dimensions - - - - -	2-23
Figure 2-17	Position of mounting plate (rear view of the inverter) Conext TL 8000 E and Conext TL 10000 E models - - - - -	2-24
Figure 2-18	Position of mounting plate (rear view of the inverter) Conext TL15000 E and Conext TL 20000 E models - - - - -	2-25
Figure 2-19	Example of fastening the mounting plate to the wall Conext TL 8000 E and Conext TL 10000 E models - - - - -	2-26
Figure 2-20	Example of fastening the mounting plate to the wall Conext TL15000 E and Conext TL 20000 E models - - - - -	2-27
Figure 2-21	Location of mounting tabs (fastening the bottom of the inverter to the wall) Conext TL 8000 E and Conext TL 10000 E models-	2-28
Figure 2-22	Location of mounting tabs (fastening the bottom of the inverter to the wall) Conext TL 8000 E and Conext TL 20000 E models-	2-28
Figure 2-23	AC plug (exploded view) - - - - -	2-31
Figure 2-24	Increasing the inner diameter of the rubber insert - - - - -	2-32
Figure 2-25	Sliding the cable nut and the back shell onto the cable - - - -	2-32
Figure 2-26	Stripping the wires - - - - -	2-33
Figure 2-27	Plug wiring- - - - -	2-34
Figure 2-28	Tightening the back shell - - - - -	2-35
Figure 2-29	Securing the AC cable - - - - -	2-35
Figure 2-30	Connecting the AC plug to the inverter and rotating the locking ring- - - - -	2-36
Figure 2-31	DC wiring polarity and connector types, for the array wiring-	2-38
Figure 2-32	Connecting the earthing conductor Conext TL 8000 E and Conext TL 10000 E models- - - - -	2-39
Figure 2-33	Connecting the earthing conductor Conext TL 15000 E and Conext TL 20000 E models- - - - -	2-40
Figure 2-34	Communication module - - - - -	2-41
Figure 2-35	Removing a plug from the end of the seal - - - - -	2-43
Figure 2-36	Inserting the cables into the seal and assembling the claw and seal- - - - -	2-43
Figure 2-37	Connecting the body of the cable gland, the claw and seal, and the sealing nut - - - - -	2-44
Figure 2-38	RS485 wiring: multiple inverters- - - - -	2-45
Figure 2-39	RJ-45 Connectors - - - - -	2-46
Figure 2-40	RS485 terminal block—pin numbering - - - - -	2-47
Figure 2-41	Termination resistor—switch numbering- - - - -	2-48
Figure 2-42	Dry contact location - - - - -	2-50

Figure 2-43	Navigating the LCD menus and screens -----	2-52
Figure 2-44	Select Country screen -----	2-53
Figure 2-45	Select Language screen -----	2-54
Figure 2-46	Main menu -----	2-54
Figure 2-47	Main menu (figure 1 of 2) -----	2-55
Figure 2-48	Main menu (figure 2 of 2) -----	2-56
Figure 2-49	Power Limit -----	2-63
Figure 2-50	Active power control -----	2-64
Figure 2-51	Frequency-dependent active power control -----	2-65
Figure 2-52	Fixed power factor -----	2-66
Figure 2-53	Power factor (Constant $\cos\phi$) -----	2-67
Figure 2-54	$\cos\phi(P)$ -----	2-68
Figure 2-55	Constant Reactive Power (Q) -----	2-69
Figure 2-56	Voltage (Q(U)) -----	2-71
Figure 2-57	Low Voltage Ride Through (LVRT) (figure 1 of 2) -----	2-73
Figure 2-58	Low Voltage Ride Through (LVRT) (figure 2 of 2) -----	2-74
Figure 2-59	Low Voltage Ride Through (LVRT) (figure 1 of 2) -----	2-76
Figure 2-60	FRD settings for Spain -----	2-78
Figure 3-1	LCD and control panel -----	3-2
Figure 3-2	Navigating the LCD menus and screens -----	3-3
Figure 3-3	Home page (E-Today) -----	3-4
Figure 3-4	Main menu -----	3-5
Figure 3-5	Menu organization -----	3-6
Figure 5-1	Loosening the screws of the fan bracket Conext TL 8000 E and Conext TL 10000 E models -----	5-3
Figure 5-2	Loosening the screws of the fan bracket Conext TL 15000 E and Conext TL 20000 E models -----	5-4
Figure 5-3	Disconnecting the fan connectors Conext TL 8000 E and Conext TL 10000 E models -----	5-4
Figure 5-4	Disconnecting the fan connectors Conext TL15000 E and Conext TL 20000 E models -----	5-5
Figure 5-5	Removing the fan bracket Conext TL 8000 E and Conext TL 10000 E models -----	5-6
Figure 5-6	Removing the fan bracket Conext TL15000 E and Conext TL 20000 E models -----	5-6
Figure 5-7	Removing the air outlet covers Conext TL 8000 E and Conext TL 10000 E models -----	5-7
Figure 5-8	Removing the air outlet covers Conext TL15000 E and Conext TL 20000 E models -----	5-8
Figure A-1	Efficiency curves 8 kVA -----	A-7

Figures

Figure A-2	Efficiency curves 10 kVA	-----	A-7
Figure A-3	Efficiency Curves 15 kVA	-----	A-8
Figure A-4	Efficiency curves 20 kVA	-----	A-8

Tables

Table 2-1	Summary chart for PV input requirements-----	2-4
Table 2-2	Packing list -----	2-12
Table 2-3	IEC color-coding to identify the phase sequence (phase rotation) -----	2-29
Table 2-4	Maximum AC cable length -----	2-30
Table 2-5	Internal Data Logger specifications -----	2-42
Table 2-6	RS485 data format -----	2-46
Table 2-7	RJ-45 pin definitions -----	2-46
Table 2-8	5-position terminal block pin definitions -----	2-47
Table 2-9	Termination resistor settings -----	2-48
Table 2-10	Buttons below the LCD -----	2-51
Table 3-1	Buttons below the LCD -----	3-3
Table 3-2	Indicator light -----	3-4
Table 4-1	Alert message descriptions -----	4-2
Table A-1	Environmental specifications -----	A-2
Table A-2	Electrical specifications -----	A-3
Table A-3	System information and communication -----	A-5
Table A-4	Regulations and directives -----	A-6
Table B-1	Text displayed on the LCD -----	B-2
Table C-1	Lookup table for country settings-----	C-2
Table C-2	Country-specific settings for Australia -----	C-3
Table C-3	Country-specific settings for Austria-----	C-3
Table C-4	Country-specific settings for Belgium-----	C-4
Table C-5	Country-specific settings for Czech -----	C-5
Table C-6	Country-specific settings for Denmark -----	C-6
Table C-7	Country-specific settings for England-----	C-6
Table C-8	Country-specific settings for France-----	C-7
Table C-9	Country-specific settings for Germany -----	C-8
Table C-10	Country-specific settings for Greece -----	C-9
Table C-11	Country-specific settings for Ireland-----	C-10
Table C-12	Country-specific settings for Israel-----	C-10
Table C-13	Country-specific settings for Italy-----	C-11
Table C-14	Country-specific settings for Netherlands-----	C-12
Table C-15	Country-specific settings for Portugal-----	C-13
Table C-16	Country-specific settings for Spain -----	C-13
Table C-17	Country-specific settings for Spain - RD1699 -----	C-14
Table C-18	Country-specific settings for Thailand -----	C-15

1

Introduction

Chapter 1, “Introduction” contains information about the features and functions of Conext TL 8000 E, Conext TL 10000 E, Conext TL 15000 E and Conext TL 20000 E photovoltaic grid tie inverters.

Description of the Conext Grid Tie Solar Inverter

The inverter converts DC power to AC power. It harvests solar energy from a PV array and exports that energy directly to a three-phase electricity grid.

The inverter provides an option to collect the maximum available energy from the PV array by constantly adjusting its output power to track the maximum power point (MPPT) of the PV array. The inverter has two MPPT channels, so that two independent PV arrays, each containing up to two paralleled inputs, can be connected to the inverter. Each PV array, having one or two PV inputs, can be loaded to different peak power points, to capture the maximum possible energy. The inverter can accommodate arrays with open circuit voltage as high as 1000 VDC.

Figure 1-1 shows the major components of a typical PV grid-tie installation, the energy flow in a system using the inverter, and the placement of typical balance-of-system components.

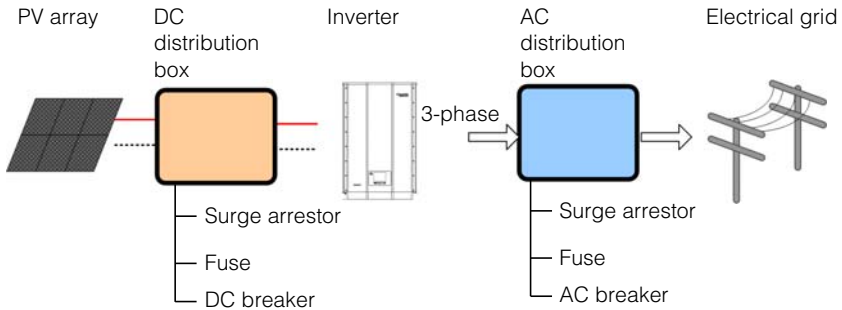

Figure 1-1 Typical installation

Installing the inverter consists of mounting it to the wall and connecting the DC input to a PV array and the AC output to the utility. For installation details, see “Installation and Configuration” on page 2–1.

Features

The inverter has the following features:

- Power ratings:
 - Conext TL 8000 E inverter: 8 kVA
 - Conext TL 10000 E inverter: 10 kVA
 - Conext TL 15000 E inverter: 15 kVA
 - Conext TL 20000 E inverter: 20 kVA
- Three-phase (3-Phase + N + PE [ground]), grid-tie, transformerless

- Wide MPPT voltage range (350-850V)
- RS485 (Modbus) communications
- IP65¹ protection class for outdoor environments
- DC (MC4) locking connectors
- Included AC connector (IP67)
- Integrated DC switch
- Maximum power conversion efficiency: > 98%
- European weighted power conversion efficiency:
 - Conext TL 8000 E inverter: 97.4%
 - Conext TL 10000 E inverter: 97.7%
 - Conext TL 15000 E inverter: 97.3%
 - Conext TL 20000 E inverter: 97.5%
- Energy harvest (MPPT) efficiency: > 99%
- Power factor adjustment range: 0.8 capacitive to 0.8 inductive
- Low AC output current distortion (THD < 3%) @ rated power
- Two independent MPP Trackers
- Logs up to 30 events
- 5-inch (diagonally) graphical display (LCD) with integrated 4-key control panel

Physical Features

Figure 1-2 shows the block diagram of Conext TL 8000 E, Conext TL 10000 E, Conext TL 15000 E and Conext TL 20000 E inverters. Figure 1-3 and Figure 1-4 shows the locations of important physical features of the inverter.

1. The IP65 enclosure is for electronics only; the balance of the enclosure is rated IP55 (for example, the ventilation cavity).

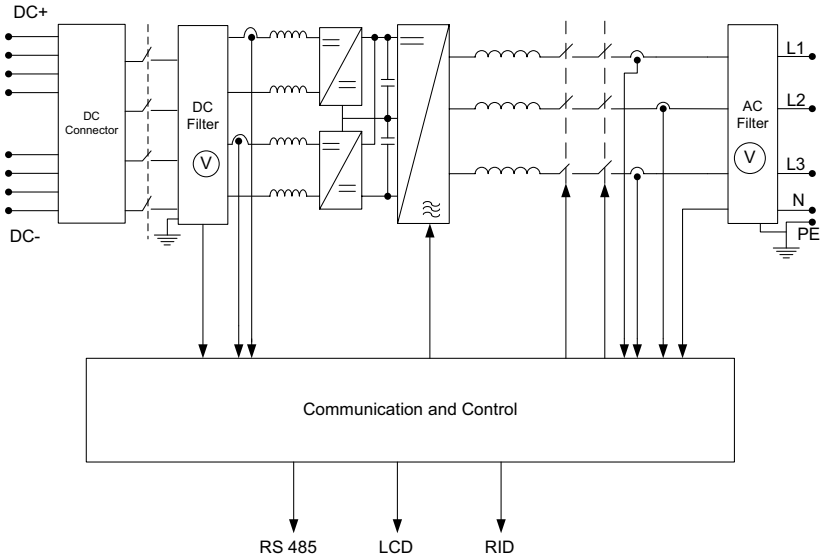

Figure 1-2 Block diagram Conext TL 8000 E, Conext TL 10000 E, Conext 15000 E and Conext 20000 E models

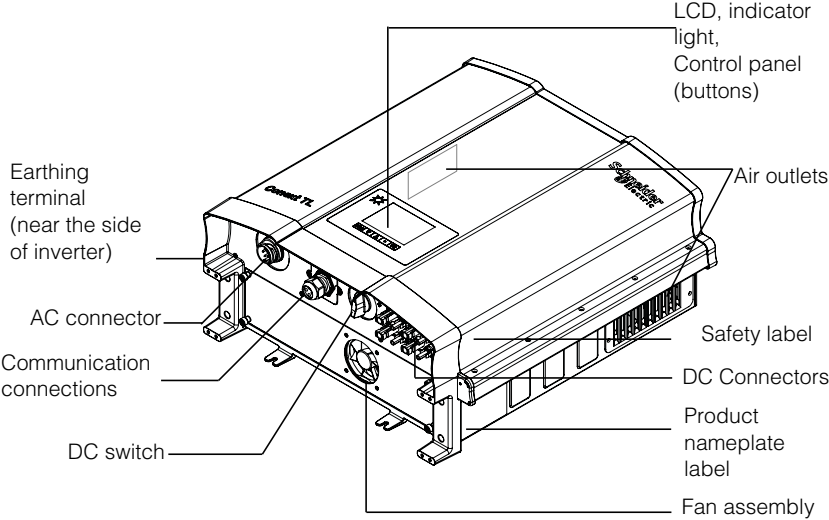

Figure 1-3 Location of important physical features Conext TL 8000 E and Conext TL 10000 E models

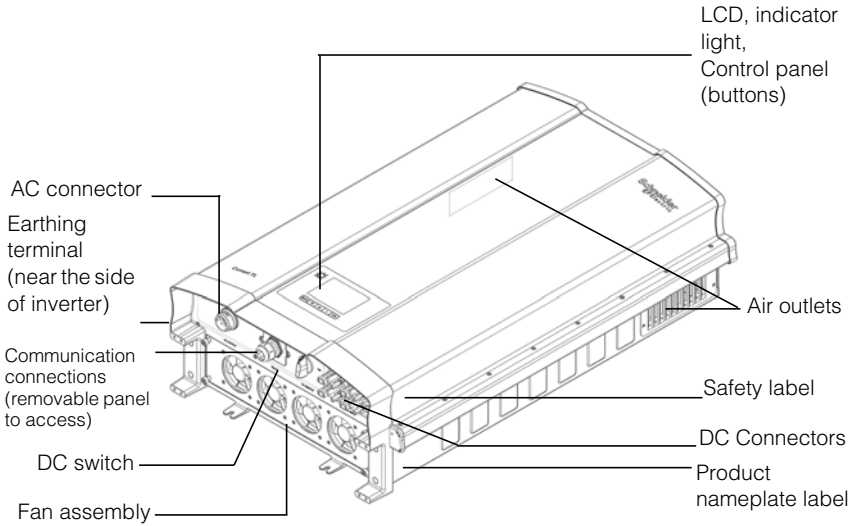

Figure 1-4 Location of important physical features Conext TL 15000 E and 20000 E models

Safety Label

The safety label is on the side of the inverter, as shown in Figure 1-3 and Figure 1-4. The label is in English, and is shown in Figure 1-5. Figure 1-6 shows the French label.

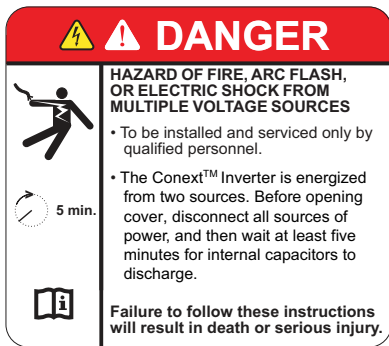

Figure 1-5 Safety label

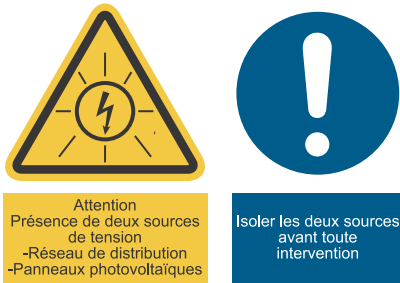

Figure 1-6 French UTE C 15-712-1 label (required for installations in France only)

In the event of installation in France, the device must be provided with the warning sticker per UTE C 15-712-1. This warning label and instructions on where to affix the label (document part # 976-0298-02-01) is included in the packaging.

Interface Panel

The connectors are located on the bottom of the inverter, and are shown in Figure 1-7 and Figure 1-8.

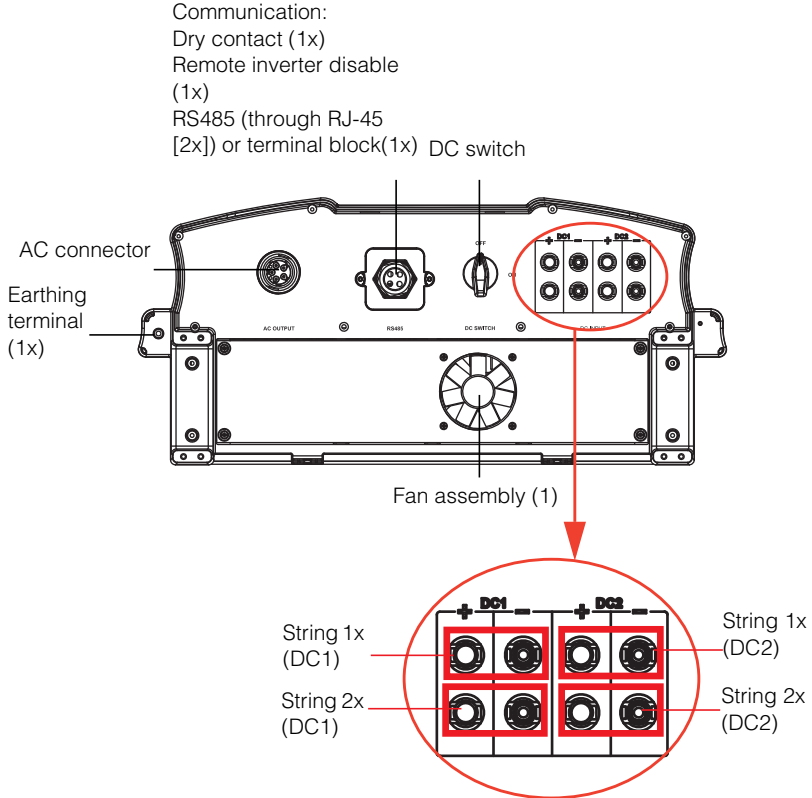

Figure 1-7 Bottom of the inverter Conext TL 8000 E and Conext TL 10000 E models

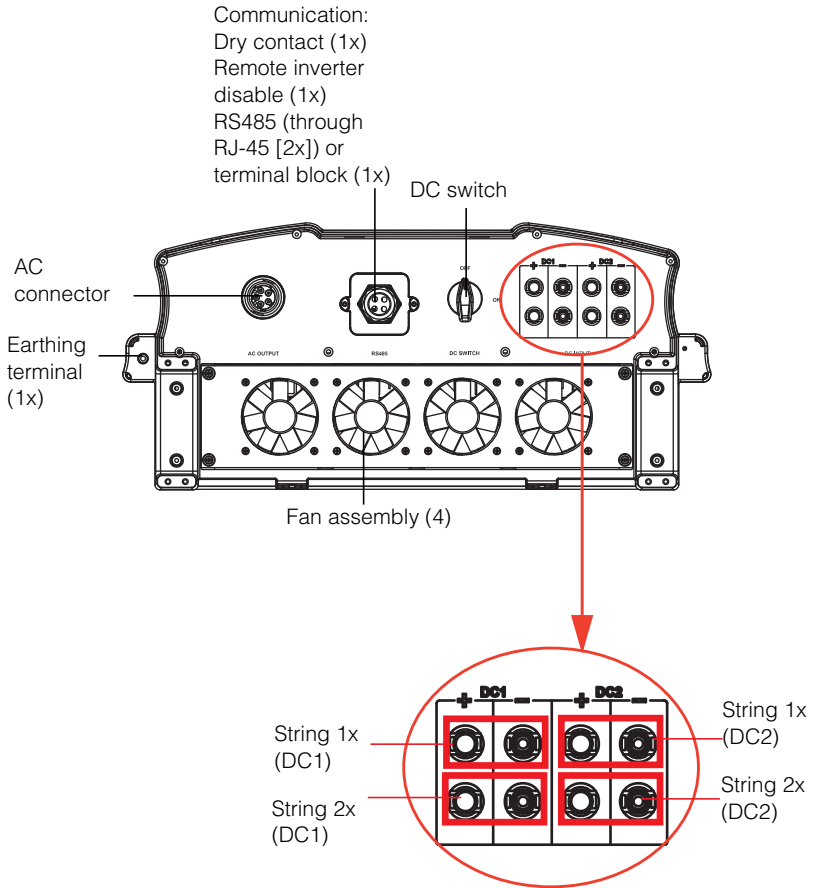

Figure 1-8 Bottom of the inverter Conext TL 15000 E and Conext TL 20000 E models

The following table shows you which sections of this manual contain information related to each item on the interface panel.

Item	See this section:
AC connector	"AC Wiring" on page 2-29
Communication connectors	"Communication Module" on page 2-41
DC switch	"Starting the Conext TL Inverters" on page 2-51
DC string connectors	"DC Wiring (From PV Array)" on page 2-37
Earthing terminal	"Earthing Terminal" on page 2-38
Fans	"Semi-Annual Maintenance" on page 5-3

2

Installation and Configuration

Chapter 2, “Installation and Configuration” provides information and procedures for installing and configuring the inverter.

Installation Overview

DANGER

HAZARD OF ELECTRIC SHOCK

- The installation procedures in this manual are for use only by qualified personnel.
- The inverter must be installed and serviced only by qualified personnel equipped with appropriate PPE.

Failure to follow these instructions will result in death or serious injury.

Planning

Planning for a system requires complete understanding of all the components that are involved to successfully install the inverter for performance and reliability, and to meet applicable installation codes.

Location

The inverter is rated and certified for both indoor and outdoor installation. See “Environmental Requirements” on page 2–10.

Clearance

Adequate ventilation and service access should be considered when installing the inverter. See “Environmental Requirements” on page 2–10.

Planning

This section provides information for you to consider before you install the inverter.

PV Planning

WARNING

HAZARD OF ELECTRIC SHOCK, FIRE, AND EQUIPMENT DAMAGE

The PV array voltage must never exceed 1000 VOC (open circuit voltage) under any condition. The Absolute Maximum PV array I_{SC} (short circuit current) must not exceed the specified limit per MPP tracker under any conditions.

Failure to follow these instructions can result in death or serious injury, and equipment damage.

A PV array sizing tool is available for download at <http://www.schneider-electric.com/products/ww/en/5300-solar-grid-tie-systems/5320-three-phase-solar/61160-conext-tl/> and select Additional links to get to Sizing tool. This software is an optional tool to help match the PV panel type and quantity to the inverter's power rating.

⚠ WARNING

HAZARD OF ELECTRIC SHOCK

Use this inverter only with PV modules that have an IEC 61730 Class A rating.

Failure to follow these instructions can result in death or serious injury.

NOTICE

RISK OF EQUIPMENT DAMAGE

Do not ground either the positive or negative conductor from the PV array.

Failure to follow these instructions can result in equipment damage.

NOTICE

RISK OF EQUIPMENT DAMAGE

- The maximum power of an array connected to DC1/DC2 must not exceed 5500 W (for the Conext TL 8000 E inverter) or 7000 W (for the Conext TL 10000 E inverter).
- The maximum power of an array connected to DC1/DC2 must not exceed 8500 W (for the Conext TL 15000 E inverter) or 11000 W (for the Conext TL 20000 E inverter).

Failure to follow these instructions can result in equipment damage.

Make sure the following requirement is met:

- Any components installed between the PV array and the inverter (for example, fuses, breakers, wiring, and connectors) must be rated at least 1000 VDC and 1.25 times the total array short circuit current nameplate rating (at STC) unless the applicable installation codes require a higher multiplier.

Table 2-1 Summary chart for PV input requirements

Parameter	Conext TL 8000 E	Conext TL 10000 E	Conext TL 15000 E	Conext TL 20000 E
Maximum input voltage, open circuit	1000 VDC			
Maximum input current per MPPT	17 A	17 A	23 A	30 A
Absolute maximum short circuit current per MPPT	24A	24 A	30 A	30 A

NOTE: For more details refer to “System Specifications” on page A-2

Recommended Protection Devices and Conductor Sizing

It is the installer’s responsibility to determine and provide the external over current protection and disconnecting means required for the PV input wiring. You must determine the need for over current protection, and its rating or setting, based on:

- Applicable installation codes
- Array currents involved
- Expected ambient temperatures
- Any other system parameters required by the installation codes

The MC4 connectors accept conductor sizes of 4 mm² or 6 mm². Select the conductor size in accordance with installation codes and to limit the connector temperature to less than 105 °C (221 °F). You must use the manufacturer’s required crimping tool PV-CZM-19100 (MC part number). For further information, contact the connector manufacturer.

<p>▲ WARNING</p> <p>HAZARD OF ELECTRIC SHOCK AND FIRE</p> <ul style="list-style-type: none"> • Use only MC4 connectors from Multi-Contact. Do not mix and match connectors from different manufacturers. • Use only the crimping tool required by Multi-Contact. <p>Failure to follow these instructions can result in death or serious injury.</p>
--

Any cable or wiring located outdoors must be outdoor rated and UV (sunlight) resistant.

NOTICE

RISK OF EQUIPMENT DAMAGE

To ensure protection class IP65, to protect against penetrating moisture and dirt, unused inputs and outputs must be properly closed with included caps.

Failure to follow these instructions can result in equipment damage.

PV Wiring Diagrams

For connection details, see Figure 2-1 and Figure 2-2. The inverter can accept PV inputs in parallel (1 MPP tracker) or separate PV input connections (2 MPP tracker).

If you are connecting several inverters, see also Figure 2-38 on page 2-45.

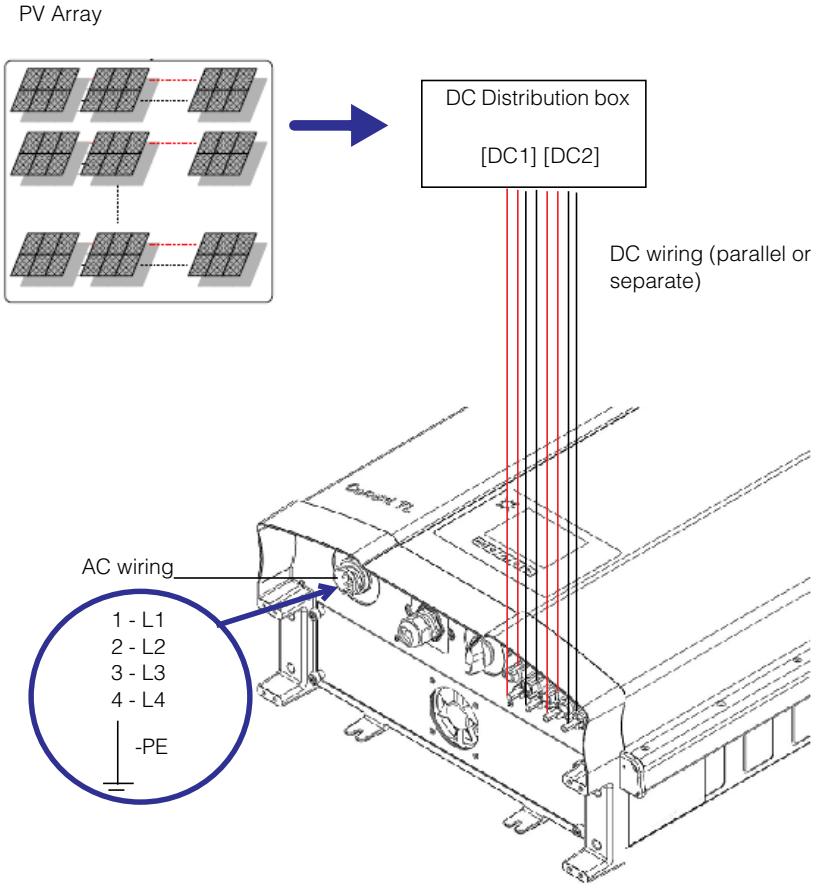

Figure 2-1 Connection diagram Conext TL 8000 E and Conext TL 10000 E models

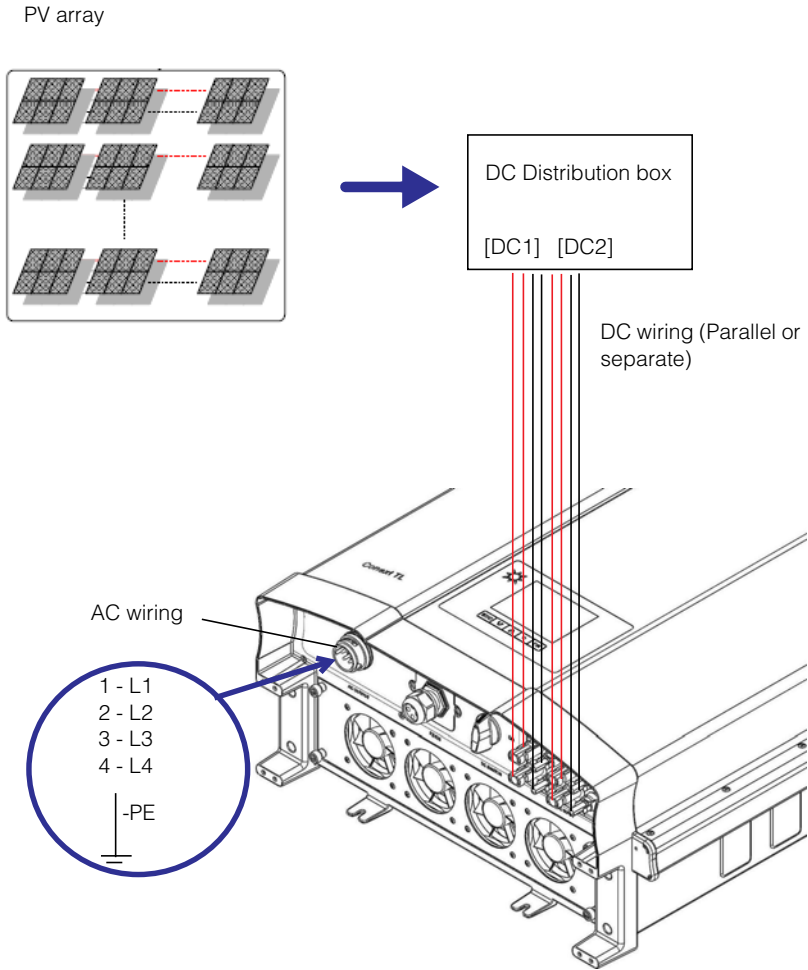
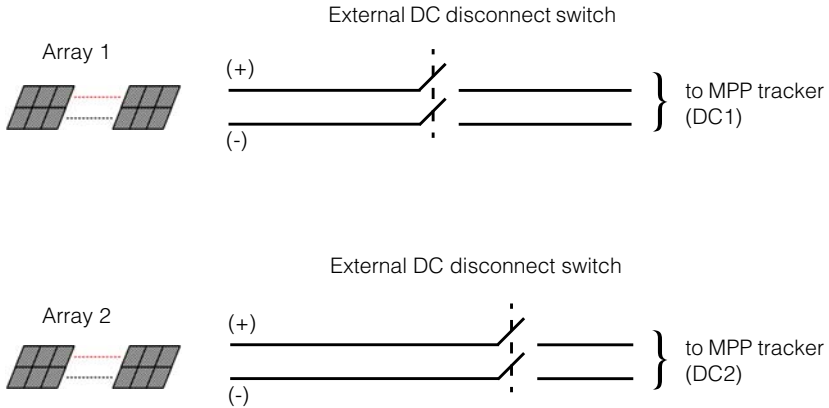

Figure 2-2 Connection diagram Conext TL15000 E and Conext TL 20000 E models

Install external DC disconnect switches. Figure 2-3 shows an example with 1 PV input per MPP tracker.



Note: DC1 and DC2 can combine (parallel) up to 2 PV inputs.

Figure 2-3 External DC disconnect switches

⚠ WARNING
<p>HAZARD OF ELECTRIC SHOCK</p> <p>The inverter's DC switch only switches off the inverter. It does not open the PV strings.</p> <p>Failure to follow this instructions can result in death or serious injury.</p>

⚠ WARNING
<p>HAZARD OF FIRE</p> <p>It is important to limit the flow of reverse current in the PV strings due to short circuit in PV module, incorrect/damaged wiring or any other issue.</p> <p>Failure to follow this instructions can result in death or serious injury.</p>

AC Grid Connection Planning

This section describes requirements regarding the AC output wiring.

Recommended Protection Devices, Conductor Type and Sizing

It is the installer's responsibility to determine and provide the external over current protection and disconnecting means required for the AC output wiring. You must determine the rating or setting of the over current protection, and the size of the conductors used, based on:

- Applicable installation codes
- Currents involved (see "Specifications" on page A-1)
- Expected ambient temperatures
- Any other system parameters required by the installation codes.

The AC cable must be jacketed and carry five insulated copper conductors to allow connection to L1, L2, L3, N, and PE (protective earth). Any cable or wiring located outdoors must be outdoor rated and UV (sunlight) resistant.

The AC connector provided is designed for AC cable outer diameters from 11 mm to 20 mm. The recommended AC cable diameter is 16 to 20 mm. The maximum cross sectional area of the AC cables is 6.0 mm² and the length of the cable shall be selected appropriately to limit the voltage drop to <1%.

It is recommended to use twisted cables to reduce the grid line inductance and for improved performance. If single core cables are used in open duct, keep the distance between cores as minimum as possible.

AC 3-phase mains branch

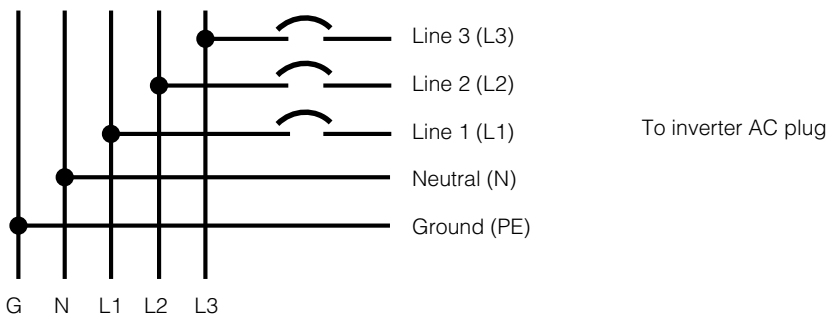

Figure 2-4 AC connection details

Conext TL inverter supports TN-S, TN-C, TN-C-S and TT connection types (earthing systems). It does not support IT connections.

Environmental Requirements

See “Environmental Specifications” on page A–2.

- The inverter’s enclosure can tolerate some ingress of dust; however, minimizing the exposure to dust may extend the life of the inverter.
- While the inverter’s IP65 enclosure¹ protects the inverter from rain and water sprayed at the inverter from a nozzle, it is recommended that outdoor installations be located away from lawn sprinklers and other sources of spray such as a hose or pressure washer.
- The inverter is designed to operate in a -20 °C to 60 °C (-4 °F to 140 °F) ambient environment. Optimal power harvest is achieved at ambient temperature between -20 °C and 40 °C. Above 40 °C, power will derate.

Choosing the Right Location for Mounting

WARNING

HAZARD OF FIRE

Keep the area under and around the inverter clear of flammable material and debris.

Failure to follow these instructions can result in death or serious injury.

CAUTION

CRUSH HAZARD

- The inverter weighs approximately 41 kg for 8 kVA and 10 kVA and 67 kg (148 lbs) for 15 & 20 kVA. Ensure that the surface on which the inverter will be mounted, and the mounting hardware used, are strong enough to support this weight.
- Use proper lifting techniques in accordance with local workplace safety rules, and always use assistance when moving or lifting.

Failure to follow these instructions can result in moderate or minor injury, or equipment damage.

¹The IP65 enclosure is for electronics only; the balance of the enclosure is rated IP55 (for example, the ventilation cavity).

NOTICE**RISK OF EQUIPMENT DAMAGE**

- The enclosure of the inverter protects internal parts from rain; however, outdoor installations must be located away from lawn sprinklers and other sources of spray such as a garden hose or a pressure washer.
- Direct sunlight on the inverter could raise internal temperatures, causing a reduction of output power during hot weather. Where possible, install the inverter in an area shaded from exposure to direct sunlight.
- Product performance might be impaired without adequate ventilation. Allow at least 600 mm (23.6 in.) clearance at the sides, top, and bottom of the inverter.
- Do not obstruct the air intakes and outlets.

Failure to follow these instructions can result in equipment damage.

Unpacking

Before you install the inverter, perform the steps in this section.

Verify the Package Contents

Before you remove the inverter, verify that the package includes all the items listed in Table 2-2.

Table 2-2 Packing list

Item	Quantity	Description
Inverter	1	Conext TL 8000 E (8 kVA), Conext TL 10000 E (10 kVA), Conext TL 15000 E (15 kVA) or Conext TL 20000 E (20 kVA) inverter
Installation and operation manual	1	This document
AC plug	1	Connector for AC connection
Mounting plate	1	Wall mounting plate to mount the inverter on the wall
French label UTE C15-712-1*	1	Safety label for units to be sold in France only. See Figure 1-6 on page 1–7

* Add UTE C15-712-1 Label if Unit is installed in France only.

Unpack the Inverter

CAUTION

CRUSH OR STRAIN HAZARD

- Use caution and correct procedures when lifting, moving, or mounting the inverter.

Failure to follow these instructions can result in death or serious injury, and equipment damage.

NOTICE

RISK OF EQUIPMENT DAMAGE

If the unit is received with the shock watch on the packing box/carton tripped, check if the inverter is damaged before receiving it from the shipper.

Failure to follow these instructions can result in equipment damage.

NOTICE**RISK OF EQUIPMENT DAMAGE**

When removing the inverter, put it on cardboard, to prevent the back surface from cosmetic damage.

Failure to follow these instructions can result in equipment damage.

To unpack the inverter:

- ◆ With the help of another person, carefully remove the inverter and place it on a flat surface. See Figure 2-6.

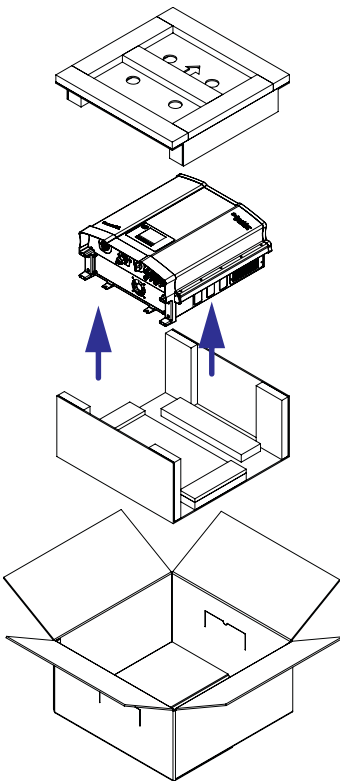
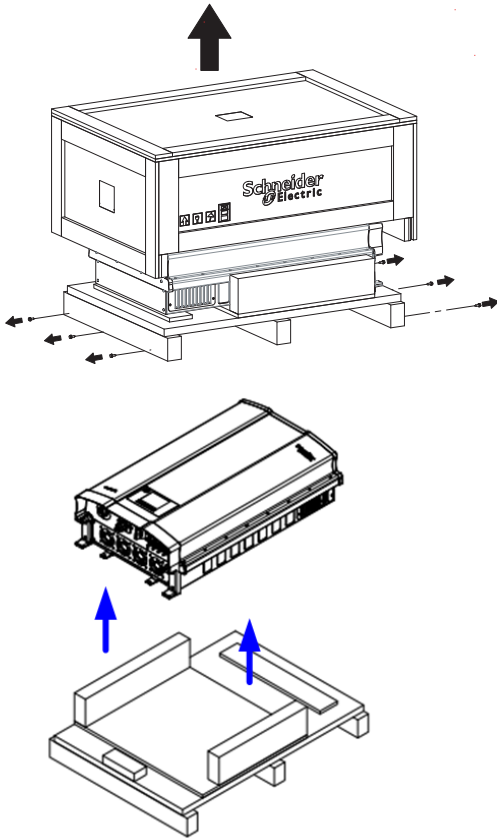

Figure 2-5 Lifting the inverter out of the crate Conext TL 8000 E and Conext TL 10000 E models



Note: Remove the screws on the sides.

Figure 2-6 Lifting the inverter out of the crate Conext TL15000 E and Conext TL 20000 E models

Check the Inverter

To check the inverter:

1. Check the inverter for damage from shipping. If it is damaged, contact Schneider Electric.
2. Check the nameplate label on the inverter to make sure it is the model you ordered. For the location of the label, see Figure 2-7 and Figure 2-8.

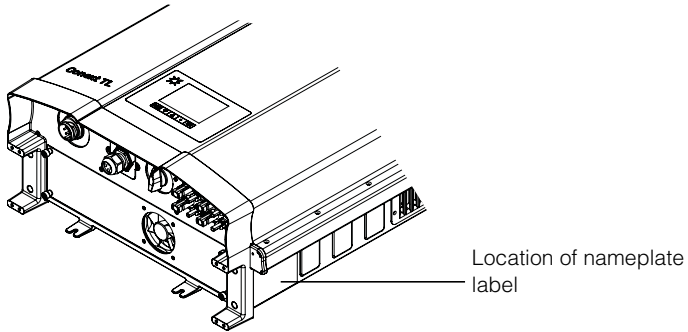

Figure 2-7 Location of nameplate label Conext TL 8000 E and Conext TL 10000 E models

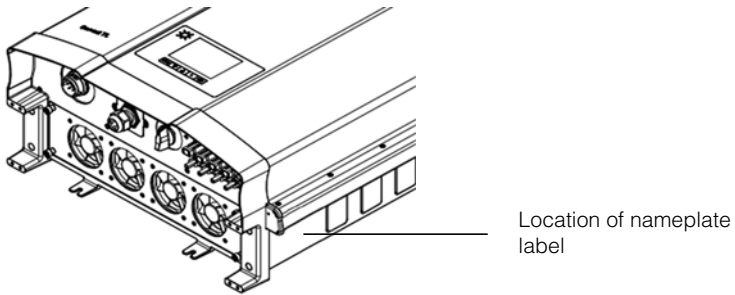

Figure 2-8 Location of nameplate label Conext TL 15000 E and Conext TL 20000 E models

3. Fill in "Information About Your System" on page D-1.

Tools Required

You will need the following tools to install the inverter.

- Slotted screwdriver
- #2 Phillips screwdriver
- Tools for preparing and connecting the wiring. See the user instructions from the connectors' manufacturers.
- Wire stripper for AC wiring
- Level for ensuring mounting bracket is straight
- Adjustable wrench to tighten AC Cable nut
- MC4 Connector removal tool

Views and Dimensions

The views and dimensions of the inverter are shown in Figure 2-9 and Figure 2-10.

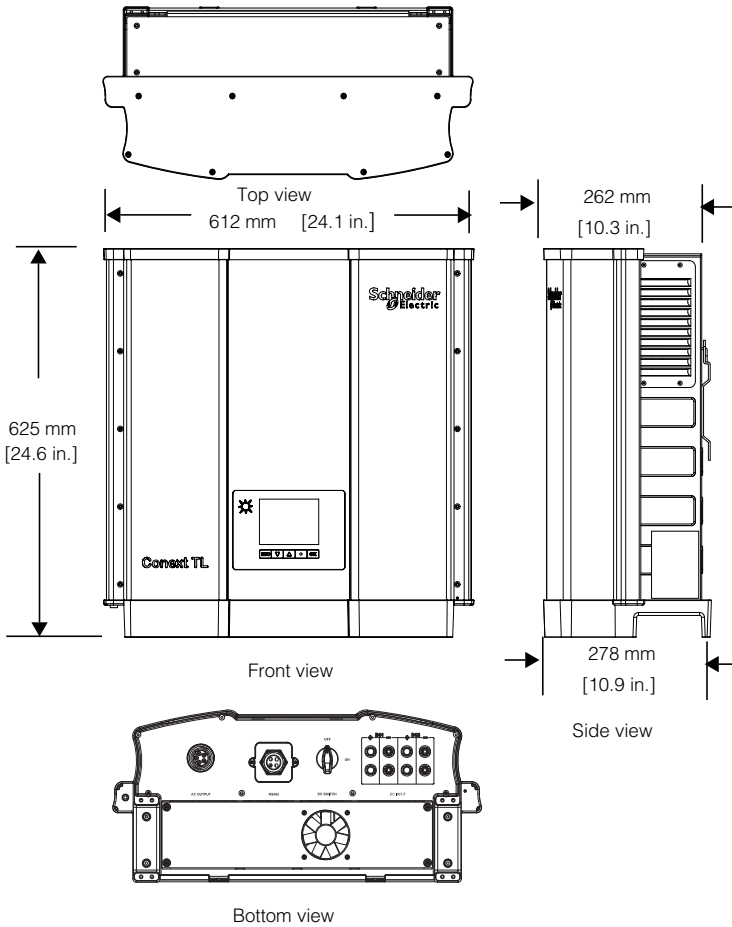

Figure 2-9 Views and dimensions Conext TL 8000 E and Conext TL 10000 E models

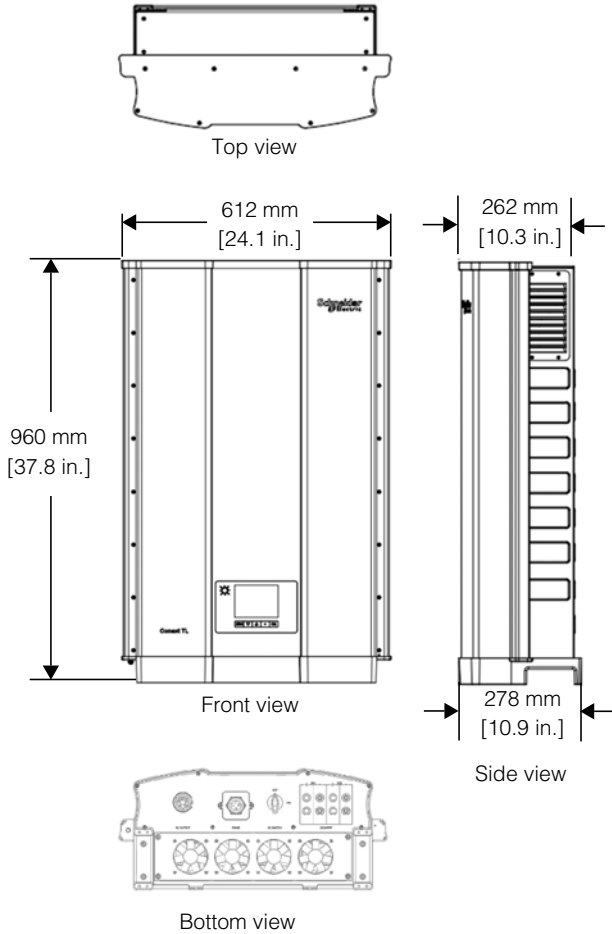

Figure 2-10 Views and dimensions Conext 15000 E and Conext TL 20000 E models

Ventilation

The air intakes are located on the bottom of the inverter, and the outlets are on the sides at the top of the inverter, as shown in Figure 2-11 and Figure 2-12.

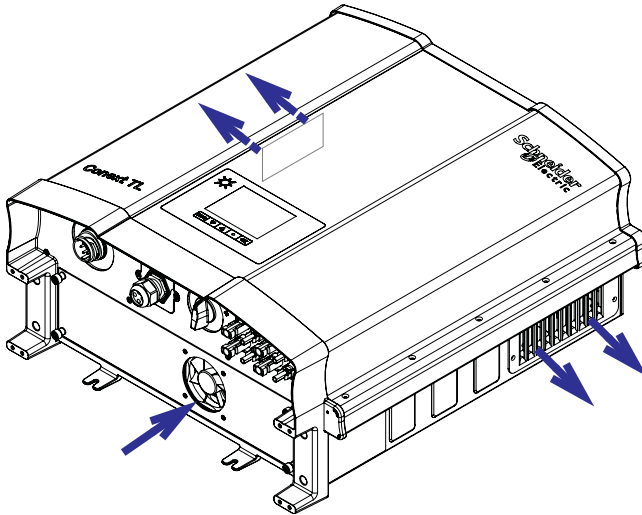

Figure 2-11 Airflow Conext TL 8000 E and Conext TL 10000 E models

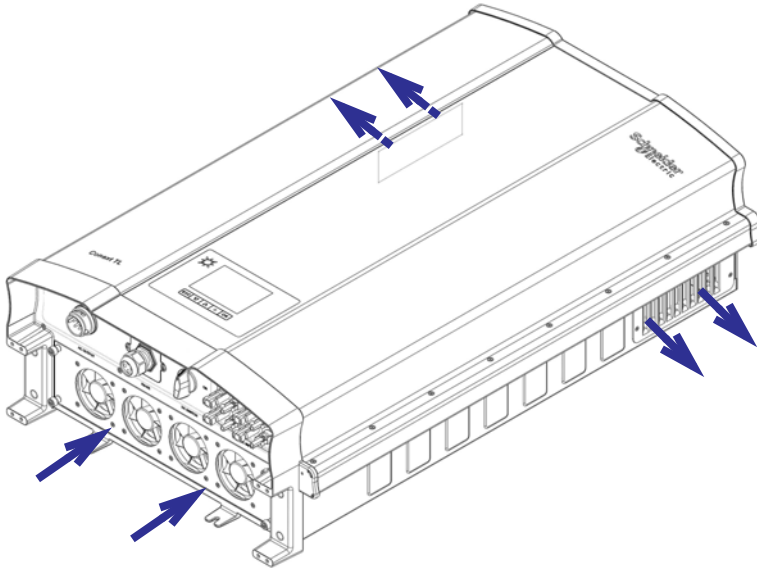

Figure 2-12 Airflow Conext TL15000 E and Conext TL 20000 E models

Mounting

This section describes how to mount the inverter.

Correct Mounting Position

⚠ WARNING

HAZARD OF ELECTRIC SHOCK

Mount the inverter only upright (fan openings facing downward) and only on a vertical surface.

Failure to follow these instructions can result in serious injury.

The correct mounting position is shown in Figure 2-13. Examples of incorrect positions are shown in Figure 2-14. The inverter does not require any clearance at the rear and it may be mounted flush on a surface. Install the device at eye level to ensure optimum user comfort.

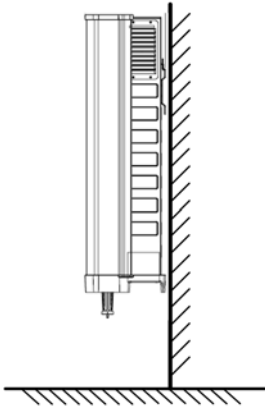
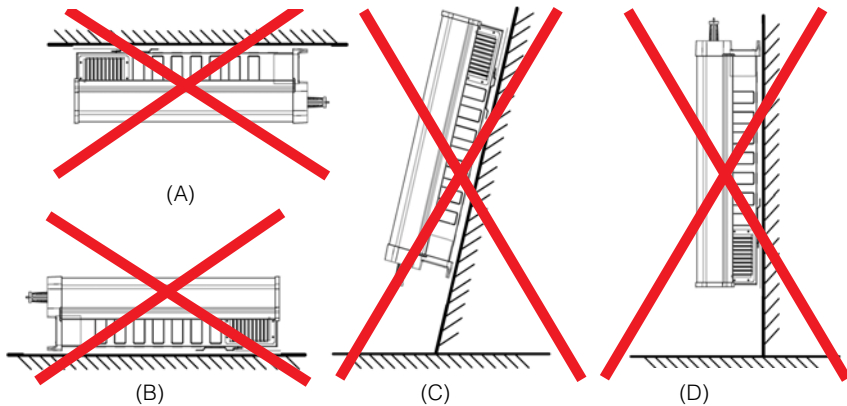

Figure 2-13 Correct mounting position



- (A) Inverter mounted hanging upside down
- (B) Inverter mounted on flat surface
- (C) Inverter mounted on slanting surface
- (D) Inverter mounted upside down with cables on top edge

Figure 2-14 Incorrect mounting positions

Proper installation distances are shown in Figure 2-15.

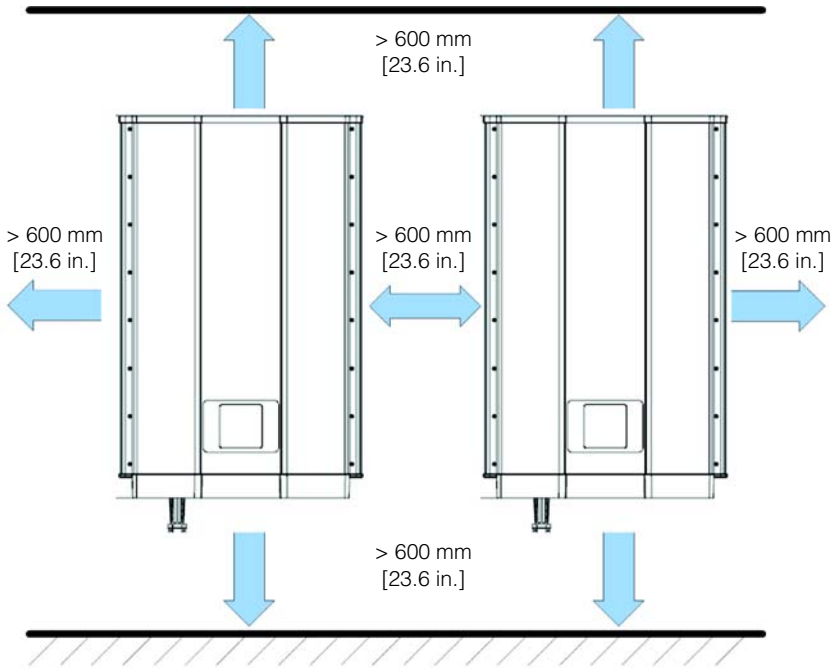

Figure 2-15 Proper installation distances Conext TL 8000 E, Conext TL10000 E, Conext TL15000 E and Conext TL 20000 E models

Mounting Plate

This section describes the mounting plate used to mount the inverter to the wall.

Dimensions of the Mounting Plate

The dimensions of the mounting plate are shown in Figure 2-16.

Side view

Wall

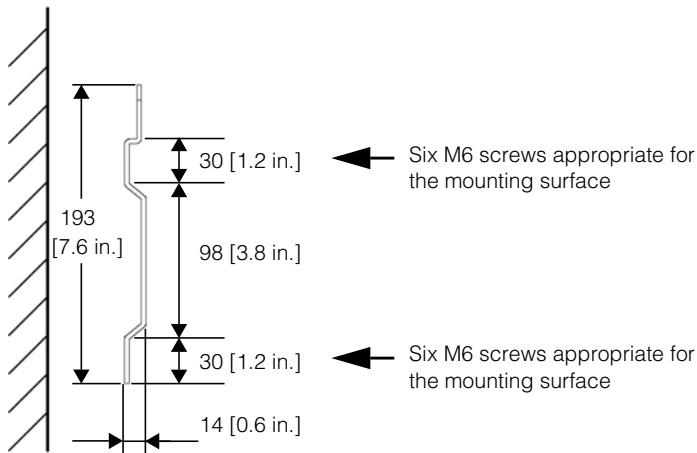

Plan view

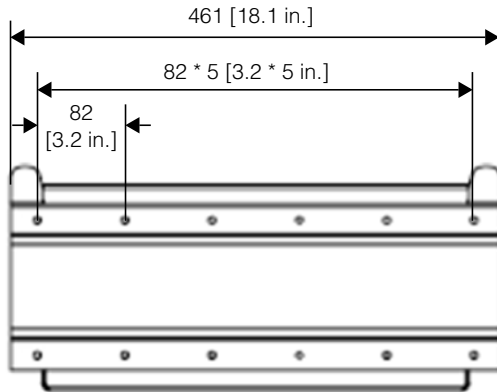

Figure 2-16 Mounting plate dimensions

Correct Position of the Mounting Plate

The correct position of the mounting plate (in relation to the inverter) is shown in Figure 2-17 and Figure 2-18.

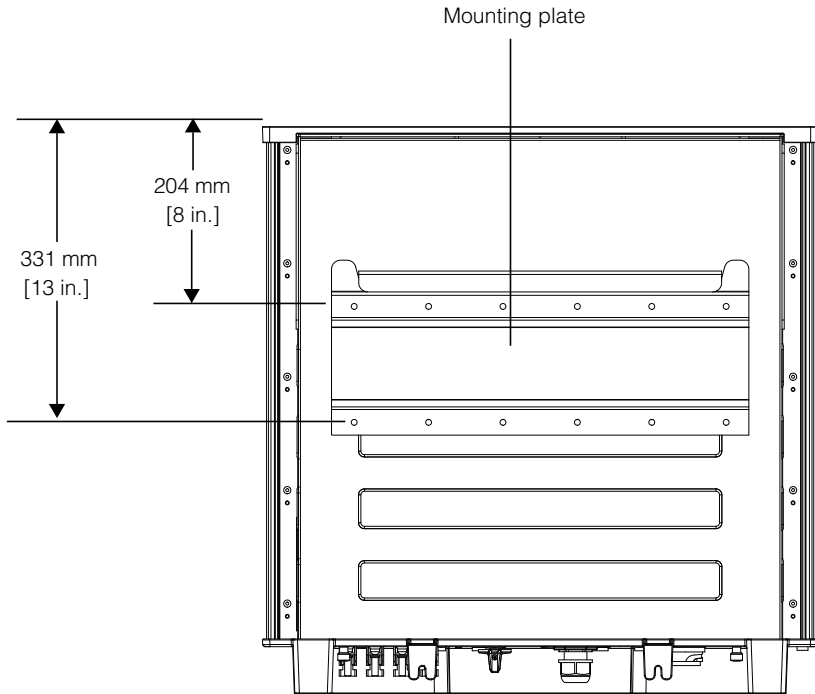

Figure 2-17 Position of mounting plate (rear view of the inverter) Conext TL 8000 E and Conext TL 10000 E models

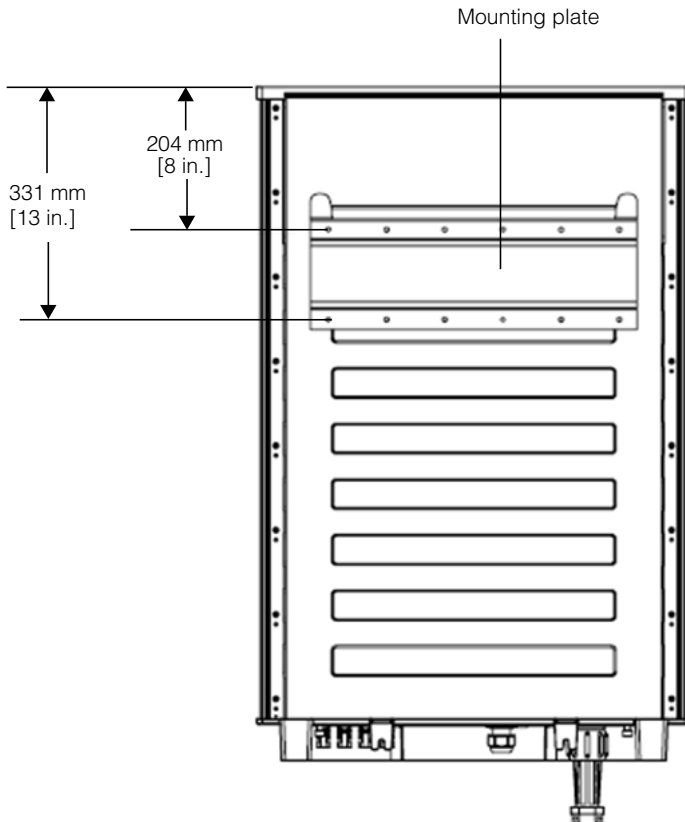
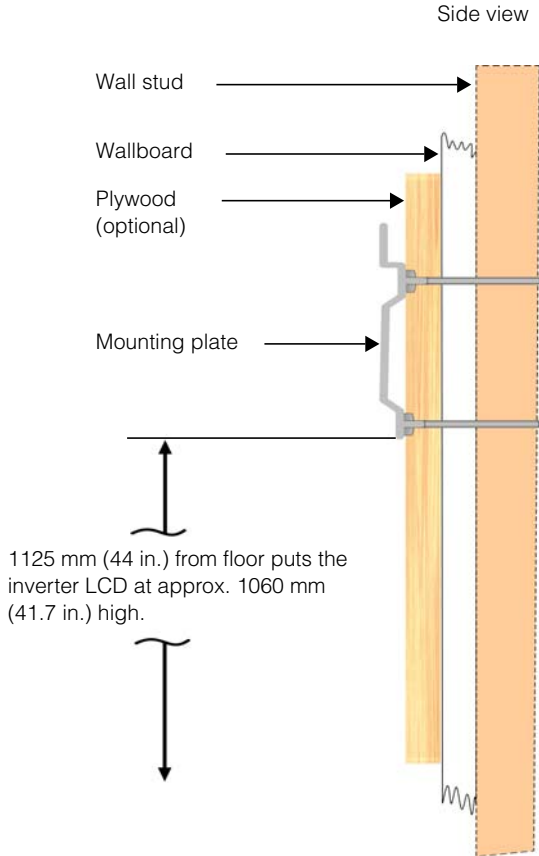

Figure 2-18 Position of mounting plate (rear view of the inverter) Conext TL15000 E and Conext TL 20000 E models

Fastening the Mounting Plate to the Wall

To fasten the mounting plate to the wall:

1. Select a wall or other suitable, solidly-built vertical surface capable of supporting the weight of the inverter and the mounting plate.
2. Using twelve M6 screws appropriate for the mounting surface you have chosen (for example, wood, concrete, or brick), securely attach the mounting plate to the mounting surface. An example of mounting on plywood, wallboard, and wall studs is shown in Figure 2-20 on page 2-27.
3. Use level to ensure mounting plate is horizontal.



- 1 Locate the wall studs.
- 2 If necessary, enhance the support surface with a plywood panel (at least 20 mm [0.8 in.] thick) secured to the wall studs. Plywood should span three wall studs.
- 3 Use hardware sized to support a minimum of 70 kg (approximately 154 lbs) (not supplied) to secure the plywood to the wall.
- 4 Using a level, secure the mounting plate to the wall. Use recommended anchoring hardware to secure the plate.

Figure 2-19 Example of fastening the mounting plate to the wall Conext TL 8000 E and Conext TL 10000 E models

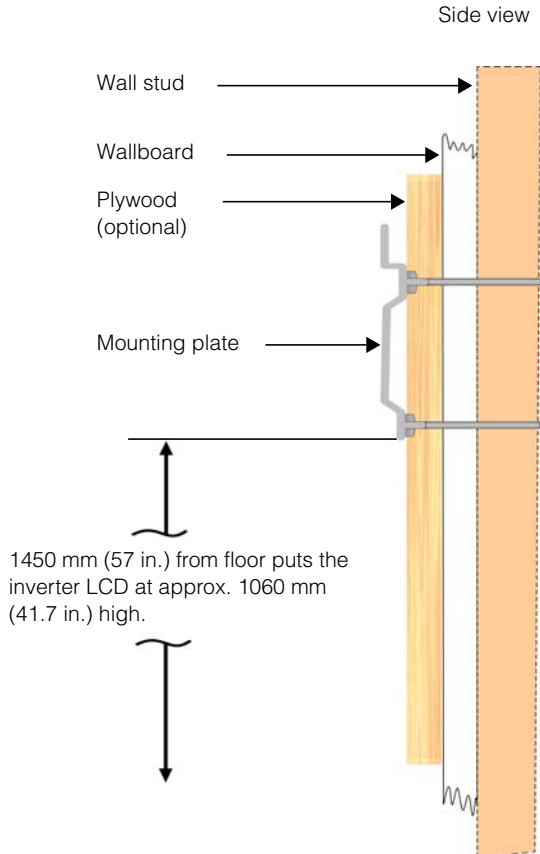

- 1 Locate the wall studs.
- 2 If necessary, enhance the support surface with a plywood panel (at least 20 mm [0.8 in.] thick) secured to the wall studs. Plywood should span three wall studs.
- 3 Use hardware sized to support a minimum of 70 kg (approximately 154 lbs) (not supplied) to secure the plywood to the wall.
- 4 Using a level, secure the mounting plate to the wall. Use recommended anchoring hardware to secure the plate.

Figure 2-20 Example of fastening the mounting plate to the wall Conext TL15000 E and Conext TL 20000 E models

Mounting the Inverter

To mount the inverter:

1. Place the inverter on the mounting plate, making sure that the upper edge of the mounting plate engages the flange on the back of the inverter.
2. Using two M6 screws appropriate for the mounting surface, fasten the bottom of the inverter to the wall. For the location of the mounting tabs, see Figure 2-21 and Figure 2-22.

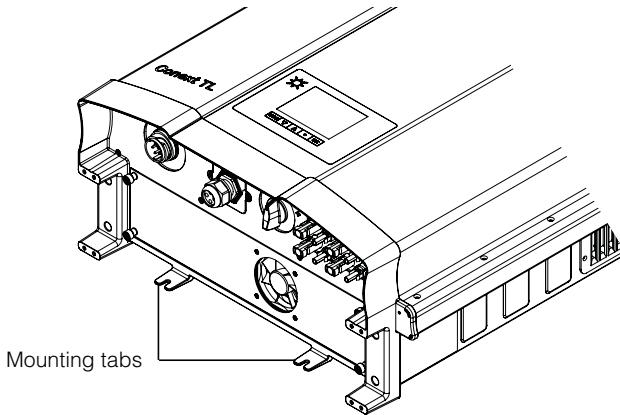

Figure 2-21 Location of mounting tabs (fastening the bottom of the inverter to the wall)
Conext TL 8000 E and Conext TL 10000 E models

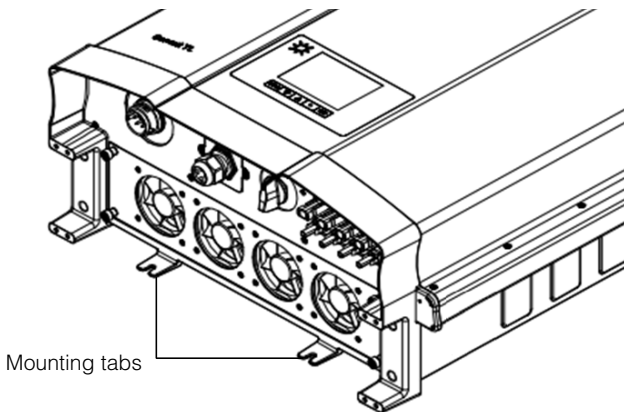

Figure 2-22 Location of mounting tabs (fastening the bottom of the inverter to the wall)
Conext TL 8000 E and Conext TL 20000 E models

Wiring

This section describes how to connect the AC wiring (to the grid) and DC wiring (from the PV array) to the inverter.

DANGER

HAZARD OF ELECTRIC SHOCK AND FIRE

- All electrical work must be done in accordance with local electrical codes.
- The Conext TL inverter has no user serviceable part inside. To be installed and serviced only by qualified personnel equipped with appropriate PPE and following safe electrical work practices.
- Before installation, de-energize the AC and PV sources using external disconnecting means provided in the installation, and test using a meter rated at least 1000 V AC and DC to make sure all circuits are de-energized. If possible, follow a lock-out tag-out procedure.
- Do not connect PV conductors until the inverter is earthed either through the AC connection or through the earthing terminal.

Failure to follow these instructions will result in death or serious injury.

AC Wiring

This section describes how to connect the inverter to the AC grid.

AC Plug Wiring

Many 3-phase AC distribution systems in Europe follow the IEC color-code to identify the different conductors and the phase sequence (phase rotation). When in doubt, use a phase rotation meter to verify.

Table 2-3 IEC color-coding to identify the phase sequence (phase rotation)

Component of AC wiring	Color
Line 1 (phase 1)	Brown
Line 2 (phase 2)	Black
Line 3 (phase 3)	Grey
Neutral	Blue
Protective earth	Green-yellow striped

NOTICE

RISK OF EQUIPMENT DAMAGE

The inverter supports positive and negative phase sequences. The sequence of L1 ~ L3 can be reversed; however, N and PE must be connected to the correct pins regardless of phase sequence.

Failure to follow these instructions can result in equipment damage.

Maximum AC Cable Length

The following table provides recommended maximum cable lengths for a 6 mm² conductor size from AC distribution box to inverter.

Table 2-4 Maximum AC cable length

Inverter	1% losses	2% losses	3% losses
Conext TL 8000 E	< 50 m	< 100 m	< 150 m
Conext TL 10000 E	< 30 m	< 60 m	< 90 m
Conext TL 15000 E	< 25 m	< 50 m	< 75m
Conext TL 20000 E	< 15 m	< 30 m	< 45 m

If the AC cable length exceeds 10 m, the use of an AC distribution box closer to the inverter is recommended. For more information, refer to “AC Grid Connection Planning” on page 2–9.

Connecting the AC Plug

To connect the AC plug:

1. Separate the AC plug into three parts, as shown in Figure 2-23 on page 2–31.
 - a) Holding the middle (central) part of the female insert, rotate the back shell to loosen it, and then detach it from the female insert.
 - b) Remove the cable nut (with rubber insert) from the back shell.

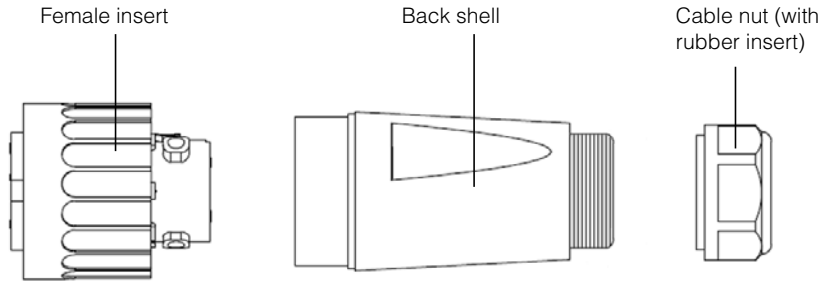

Figure 2-23 AC plug (exploded view)

2. If the diameter of the AC cable you are using is 16 mm or larger:
 - ◆ Using a flat screwdriver, carefully break the connection between the two rubber rings that make up the rubber insert, as shown in Figure 2-24 on page 2-32. Discard the inner ring (to increase the inner diameter of the rubber insert).

NOTICE

RISK OF EQUIPMENT DAMAGE

If you have damaged the outer ring and the inverter will be used outdoors, obtain a replacement rubber insert from Schneider Electric, and then repeat the above steps.

Failure to follow these instructions can result in equipment damage.

Before:

After:

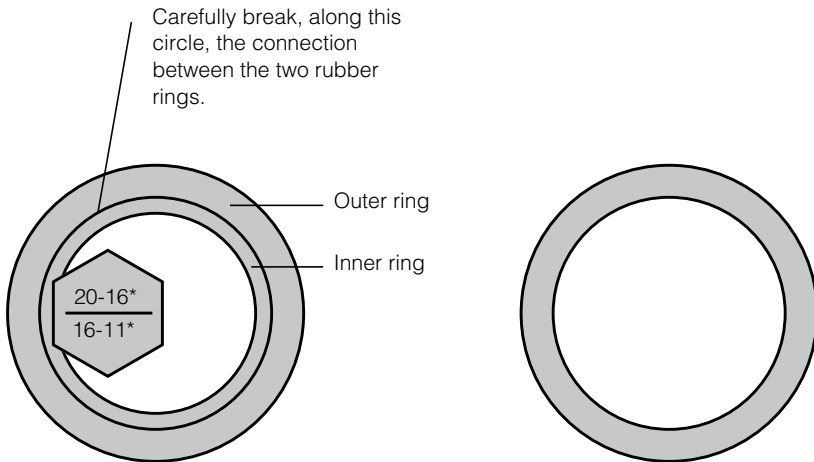

Note: *The values shown are the OD values of the AC cable used

Figure 2-24 Increasing the inner diameter of the rubber insert

3. Slide the cable nut and then the back shell onto the cable, as shown in Figure 2-25.

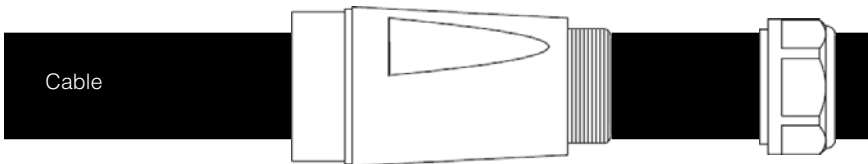

Figure 2-25 Sliding the cable nut and the back shell onto the cable

4. Using the appropriate tool, strip the wires:

⚠ DANGER

HAZARD OF ELECTRIC SHOCK

- Make sure you do not accidentally cut the wire insulation and expose the wires (other than the stripped ends).
- Make sure you follow the recommended specifications of stripping/trimming of the wires.

Failure to follow these instructions will result in death or serious injury.

- a) Remove 55 mm (2.2 in.) of the outer jacket (shown in Figure 2-26).

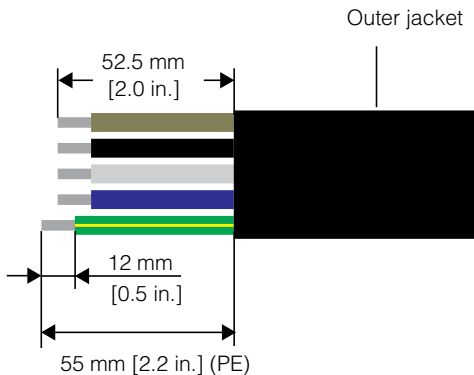
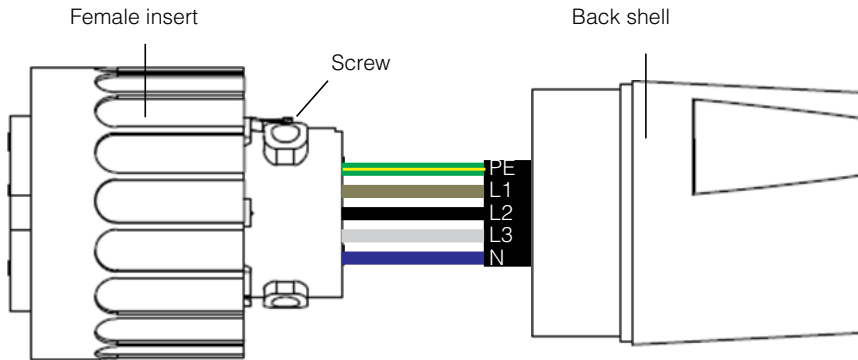
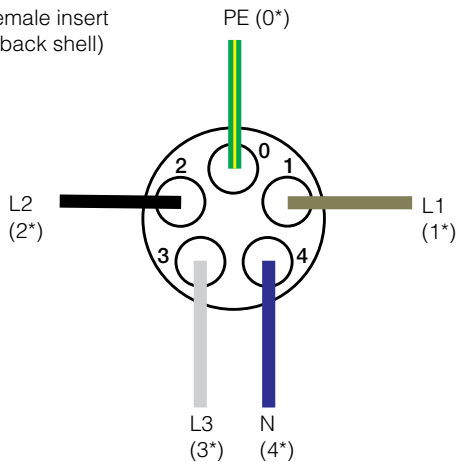

Figure 2-26 Stripping the wires

- b) Trim all the wires, except the PE wire, to 52.5 mm (2.0 in.).
- c) Using the appropriate tool, strip 12 mm (0.5 in.) of insulation from all wire ends, as shown in Figure 2-26 (above).
5. Insert the stripped end of each of the five wires into the appropriate hole in the female insert, and then tighten each screw to 0.7 Nm (to hold each wire in place). See Figure 2-27 on page 2-34.



End view of female insert
(viewed from back shell)



* Numbers are embossed on the connector.

Figure 2-27 Plug wiring

⚠ DANGER

HAZARD OF ELECTRIC SHOCK

Make sure you do not mistakenly connect a phase conductor to the PE terminal (#0)—otherwise the chassis will be energized at 230 VAC.

Failure to follow these instructions will result in death or serious injury.

6. Slide the back shell towards the female insert.
7. Holding the middle (central) part of the female insert, rotate the back shell to connect it to the female insert and then tighten it, as shown in Figure 2-28.

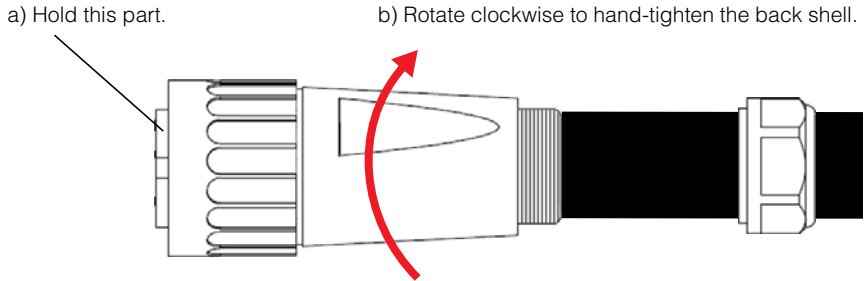

Figure 2-28 Tightening the back shell

8. Slide the cable nut towards the back shell.
9. Rotate the cable nut to secure the cable, as shown in Figure 2-29.

Rotate the cable nut clockwise to secure the cable (tighten to 5 Nm)

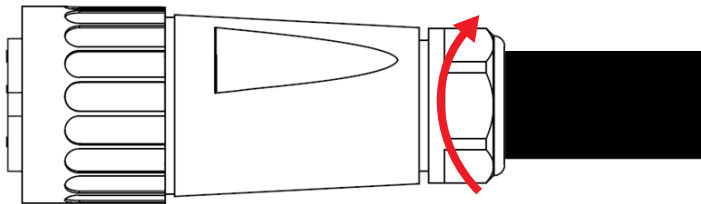

Figure 2-29 Securing the AC cable

▲ WARNING

HAZARD OF FIRE

To prevent damage to wire strands and their subsequent overheating, make sure you properly install and tighten the cable nut onto the AC plug assembly.

Failure to follow these instructions can result in death or serious injury.

NOTE: Make sure that the AC plug and cable are fully assembled before you connect them to the inverter.

10. Connect the AC plug to the inverter, and then rotate the locking ring of the female insert to secure the plug to the inverter. See Figure 2-30.

▲ WARNING

HAZARD OF ELECTRIC SHOCK AND FIRE

Ensure the AC plug is properly connected with the locking ring tightened.

Failure to follow these instructions can result in death or serious injury.

NOTICE

RISK OF EQUIPMENT DAMAGE

Do not cross-thread the male and female connector. It can damage the connector if cross-threaded.

Failure to follow these instructions can result in equipment damage.

Inverter

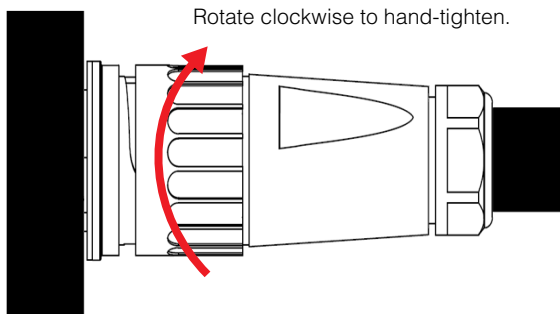

Figure 2-30 Connecting the AC plug to the inverter and rotating the locking ring

11. Using insulated cable clamps, secure the cable to the wall or structure.

▲ WARNING**HAZARD OF ELECTRIC SHOCK**

Make sure the clamp nearest the inverter is at a distance that:

- Allows the AC plug to be connected and disconnected from the inverter.
- Does not allow the AC plug to reach the ground or other surface under the inverter where water might collect.

Failure to follow these instructions can result in death or serious injury.

DC Wiring (From PV Array)**▲ WARNING****HAZARD OF ELECTRIC SHOCK AND FIRE**

- Use only MC4 connectors from Multi-Contact. Do not mix and match connectors from different manufacturers.
- Use only the crimping tool (MC part # PV-CZM-19100) required by Multi-Contact.
- Do not disconnect MC4 connectors under load.

Failure to follow these instructions can result in death or serious injury.

DC Wiring Polarity**NOTICE****RISK OF EQUIPMENT DAMAGE**

- Make sure the correct polarity is used for all power connections.
- In case of reverse polarity of DC, there is a protection by diode. There is no damage involved for the inverter. The array will be shorted: No DC voltage on the MPPT input and the PV generator will be in short circuit condition.
- Do not ground either the (+) or the (-) conductor of the PV array.

Failure to follow these instructions can result in equipment damage.

The PV wiring connects to the inverter using polarized connectors. The polarity of the connectors to be used on the wiring to the inverter is shown in Figure 2-31. Your inverter has the correct connectors to mate with the connectors shown.

Type: PV-KBT4/6 II, from Multi-Contact AG (www.multi-contact.com)

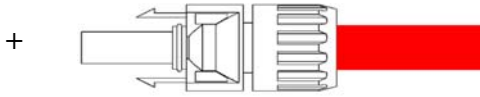

Type: PV-KST4/6 II, from Multi-Contact AG

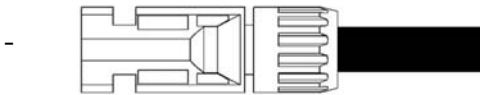

Figure 2-31 DC wiring polarity and connector types, for the array wiring

Connection

To connect the PV wires:

1. Follow the manufacturer's instructions to assemble the MC4 connectors onto the PV wiring. Make sure you use the right connector polarities, as shown in Figure 2-31 on page 2–38.
2. Connect the wires to the DC1 and DC2 connectors of the inverter.
3. Using insulated cable clamps, secure the PV cables to the wall or structure.
4. Remove caps from MC4 terminals. It is recommended to close the unused open inputs with the included MC4 terminal caps.

⚠ WARNING

HAZARD OF ELECTRIC SHOCK

Make sure the clamps nearest the inverter are at a distance that:

- Allows the plugs to be connected and disconnected from the inverter.
- Does not allow the plugs to reach the ground or other surface under the inverter where water might collect.

Failure to follow these instructions can result in death or serious injury.

Earthing Terminal

The use of this earthing terminal depends upon local installation codes. It can be used to connect the PV metalwork to earth, or to provide a second protective ground connection for the inverter chassis as required by some countries. It is the responsibility of the installer to determine proper use of this terminal. See Figure 2-32 and Figure 2-33.

NOTE: Use 2.5 mm² earthing conductor for Conext TL 8000 E and Conext TL 10000 E and a 6 mm² earthing conductor for Conext TL 15000 E and Conext TL 20000 E.

▲ WARNING

HAZARD OF ELECTRIC SHOCK

If the PV metalwork grounding is done at the inverter, removal of the inverter or disconnection of the AC plug from the inverter will leave the PV metalwork not grounded; you must provide temporary additional grounding.

Failure to follow these instructions can result in death or serious injury.

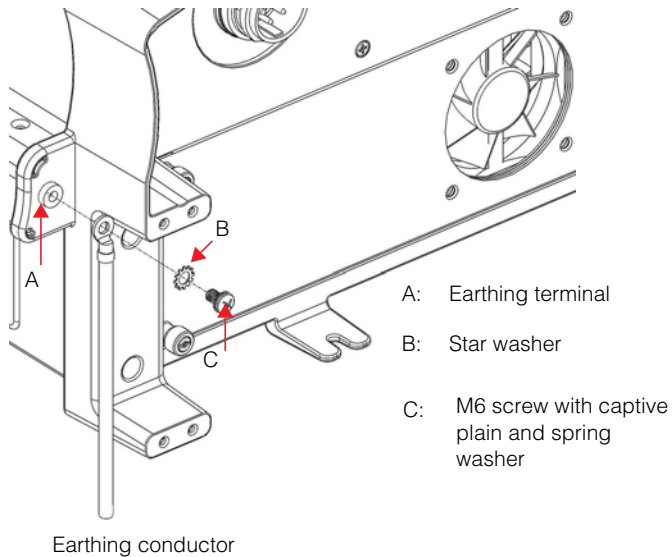

Figure 2-32 Connecting the earthing conductor Conext TL 8000 E and Conext TL 10000 E models

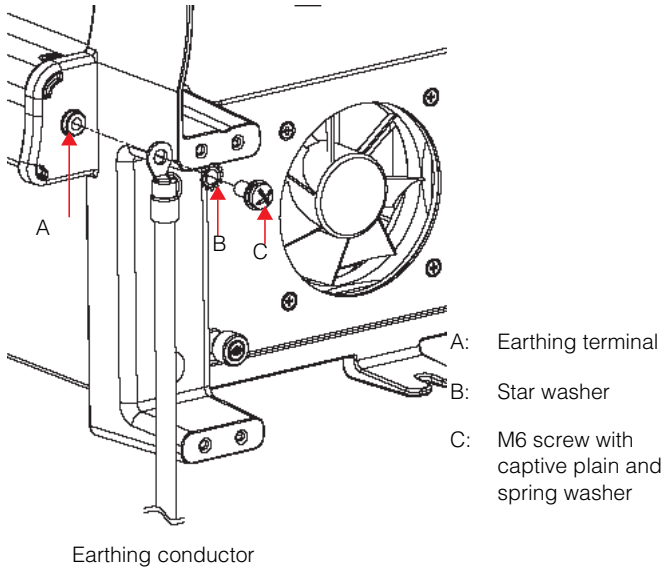

Figure 2-33 Connecting the earthing conductor Conext TL 15000 E and Conext TL 20000 E models

Communication Module

▲ WARNING

HAZARD OF ELECTRIC SHOCK

- Connect only to Safety Extra Low Voltage (SELV) circuits.
- The circuits provided for use with external communications and control equipment are designed to provide isolation from neighbouring hazardous circuits within the inverter. The communications and control circuits are classified as Safety Extra Low Voltage (SELV) and must only be connected to other SELV circuits of the types described in this manual.
- Physical and electrical separation of the communications and control circuits from non-SELV electrical circuits must be maintained both within the inverter and outside the inverter.

Failure to follow these instructions can result in death or serious injury.

The communication module supports the Modbus communication protocol via an RS485 interface. The module also provides an RID (Remote Inverter Disable) input and a dry (not energized) contact for signalling purposes. The module is shown in Figure 2-34.

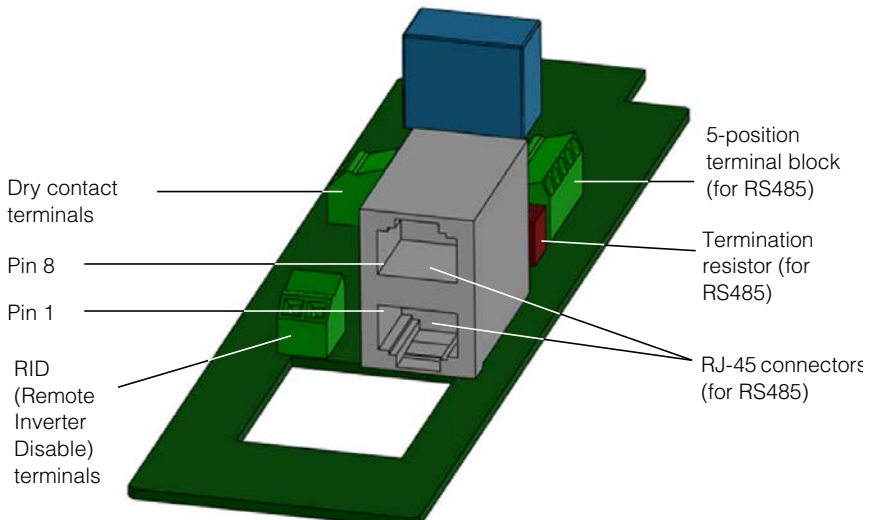

Figure 2-34 Communication module

Removing the Communication Module

DANGER

HAZARD OF ELECTRIC SHOCK AND FIRE

- All electrical work must be done in accordance with local electrical codes.
- The Conext TL inverter has no user serviceable parts inside. To be installed and serviced only by qualified personnel equipped with appropriate PPE and following safe electrical work practices.
- Before installation, de-energize the AC and PV sources using external disconnecting means provided in the installation, and test using a meter rated at least 1000 V AC and DC to make sure all circuits are de-energized. If possible, follow a lock-out tag-out procedure.
- Do not connect PV conductors until the inverter is earthed either through the AC connection or through the earthing terminal.

Failure to follow these instructions will result in death or serious injury.

To remove the communication module:

1. Turn the DC switch to the “OFF” position. For the switch location, see Figure 1-8 on page 1-9.
2. Wait at least 1 minute for internal voltages to discharge, and then disconnect the AC plug and all PV connectors from the inverter, being careful not to allow water or dirt to contact any of connectors.
3. Remove the two screws—one on each side of the connector labeled “RS485” (above the second fan on the interface panel). For the connector location, see Figure 1-8 on page 1-9.
4. Pull the cover off.
5. Remove the communication module.

Internal Data Logger

Table 2-5 Internal Data Logger specifications

Recording Cycle	Storage Time
1 record/5 minute	1 day
1 record/15 minutes	1 month
1 record/1 day	1 year
1 record/1 month	10 years

Connecting Cables to the Communication Module

NOTE: The drawings in this section show one cable being connected. You can connect several cables to the communication module.

To connect the cables:

1. For each cable you will be connecting, pull one of the plugs out of the end of the seal, as shown by the arrow in Figure 2-35.

NOTICE

RISK OF EQUIPMENT DAMAGE

To make sure the seal is not compromised, remove only the number of plugs equal to the number of cables you will be connecting.

Failure to follow these instructions can result in equipment damage.

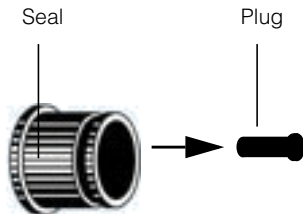

Figure 2-35 Removing a plug from the end of the seal

2. Insert the cables into the seal, and then assemble the claw and seal, as shown in Figure 2-36.
The outside of the seal has one cut, down the length of the seal, for each of the plugs. This is for easy insertion of the cable.

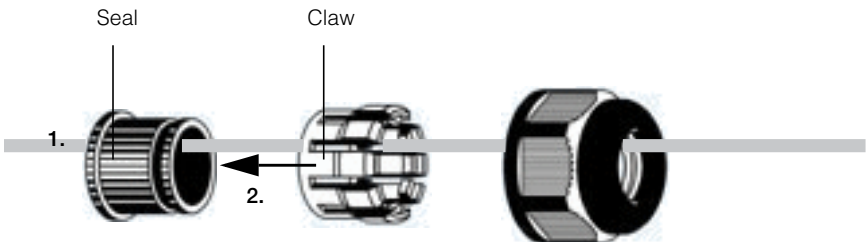

Figure 2-36 Inserting the cables into the seal and assembling the claw and seal

3. For each cable, leave 100 to 170 mm (3.9 to 6.7 in.) from the end of the cable to the seal. This is to provide enough cable to reach the connector on the communication module when the module is inserted in the inverter.
4. Connect the body of the cable gland to the claw and seal, as shown in the left part of Figure 2-37.

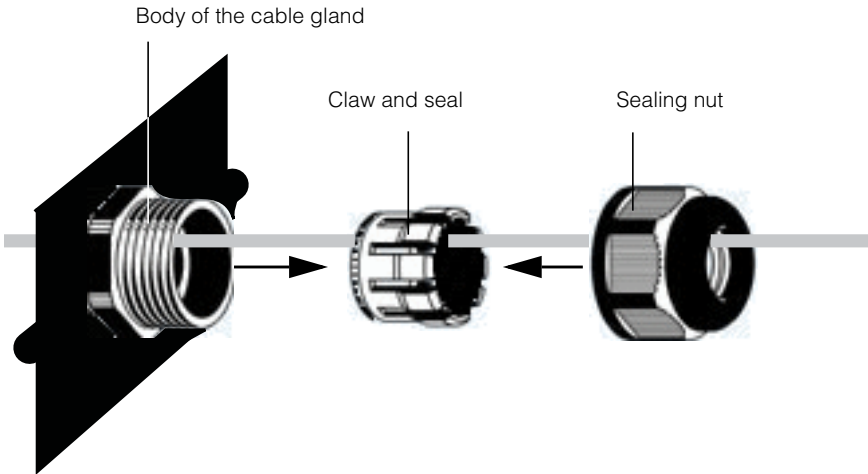

Figure 2-37 Connecting the body of the cable gland, the claw and seal, and the sealing nut

5. Slide the sealing nut towards the body of the cable gland with claw and seal (as shown in the right part of Figure 2-37), and then hand-tighten the sealing nut onto the body.
6. Connect the end of each cable to the appropriate connector on the communication module.
7. Insert the communication module into the inverter.
8. Attach the cover of the communication module slot to the inverter. Tighten each of the two captive screws to 0.7 Nm.

RS485 Connection

NOTICE

RISK OF EQUIPMENT DAMAGE

Make sure the other end of the RS485 connection is also RS485. Connection to any other type of communication port, such as Ethernet, may result in equipment damage.

Failure to follow these instructions can result in equipment damage.

Two options are available for implementing the RS485 connection:

- Using either or both of the two RJ-45 connectors. See the following section “RS485 Connection Using the RJ-45 Connectors” on page 2–46.
- Using the 5-position terminal block. See “RS485 Connection Using the 5-Position Terminal Block” on page 2–47.

NOTE: Use Category 5 shielded twisted pair cable AWG 24 with one twisted pair and at least a third conductor.

The wiring when using multiple inverters is shown in Figure 2-38.

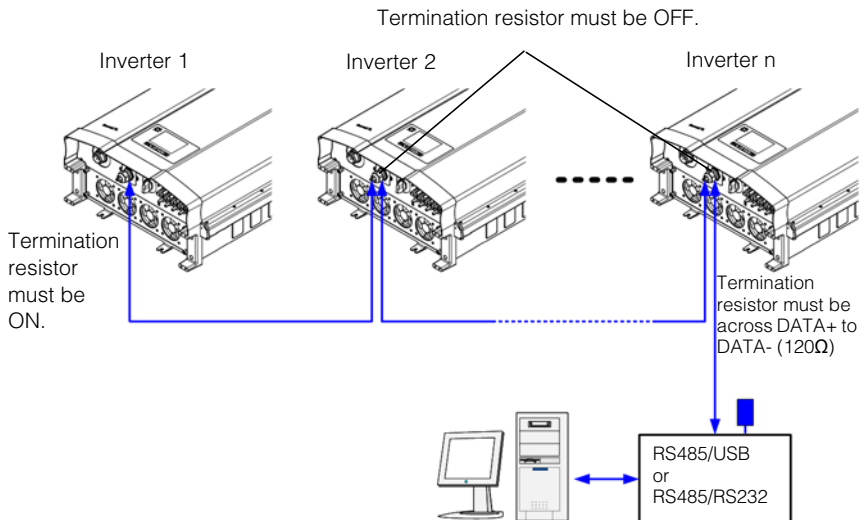

Note: Number of inverters connected in parallel is recommended to be limited to 32.

Figure 2-38 RS485 wiring: multiple inverters

The data format for the RS485 connection is shown in Table 2-6.

Table 2-6 RS485 data format

Parameter	Value
Baud rate	9600
Data bits	8
Stop bits	1
Parity	None

RS485 Connection Using the RJ-45 Connectors

The pin definitions of the RJ-45 connection are shown in Table 2-7. For the location of pin 8, see Figure 2-34 on page 2-41. Figure 2-39 illustrates RJ-45 pin definitions.

Table 2-7 RJ-45 pin definitions

Pin	Function
4	DATA+
5	DATA-
7	NC (Not connected)
8	Modbus ground

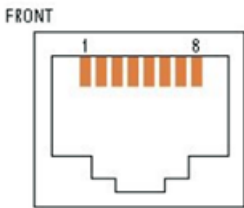

Figure 2-39 RJ-45 Connectors

RS485 Connection Using the 5-Position Terminal Block

The pin definitions of the 5-position terminal block are shown in Table 2-8.

Table 2-8 5-position terminal block pin definitions

Pin	Function
1	DATA+
2	DATA-
3	Chassis ground
4	Modbus ground
5	NC (Not connected)

The location of the terminal block is shown in Figure 2-34 on page 2-41.

For pin numbering, see Figure 2-40.

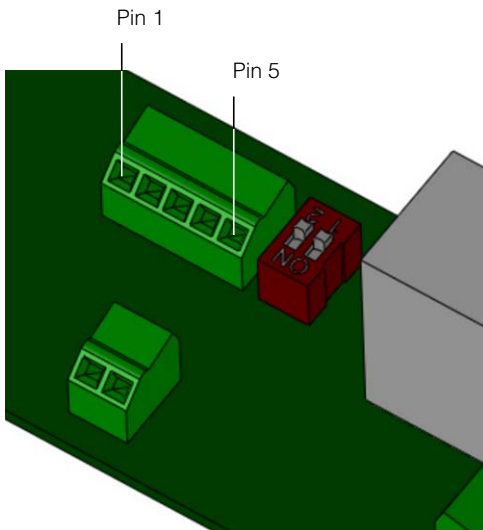

Figure 2-40 RS485 terminal block—pin numbering

Termination Resistor

If the inverter is the first or the last device of the RS485 chain, set the termination resistor to on; otherwise, set it to off. The location of the termination resistor is shown in Figure 2-41. The settings are shown in Table 2-9.

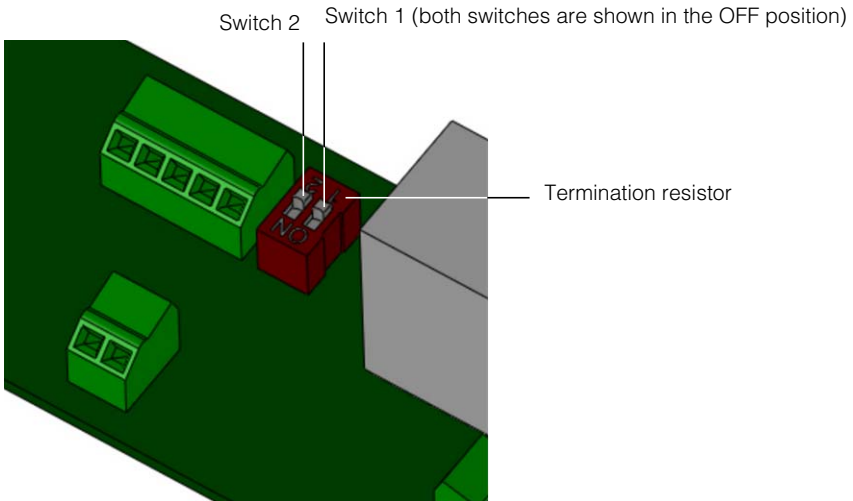

Figure 2-41 Termination resistor—switch numbering

Table 2-9 Termination resistor settings

Switch 1	Switch 2	Result
Off	Off	The termination resistor is off.
Off	On	The termination resistor is on.
On	Off	The termination resistor is on.
On	On	The termination resistor is on.

RID (Remote Inverter Disable) Input Connection

The inverter has one optional Remote Inverter Disable (RID) connection available from a two-terminal screw terminal block. This input is intended to be connected to dry (non-energized) switch or relay contacts. The external contacts must be capable of switching 30 mA at 12 VDC. The location of the RID connection is shown in Figure 2-34 on page 2-41.

NOTE: On the communication module, the RID connection is labelled as "EPO".

During inverter operation, these pins are normally not connected together. With the RID feature, connecting these pins together (by the use of a remote contact, such as a relay or switch) causes the internal AC power contactors of the inverter to open and the inverter to shut down.

▲ WARNING

HAZARD OF ELECTRIC SHOCK

Do not remove any covers. Operating the RID (Remote Inverter Disable) circuit or the switch on the inverter does not remove all power from the inverter. Internal parts and the external wiring remain live unless the PV and AC circuits have been disconnected externally.

Failure to follow these instructions can result in death or serious injury.

If you do not want to use the RID feature, do not connect anything to the RID terminals. This will leave the inverter operating normally, controlled by the DC switch of the inverter, by the inverter controls, and by RS485 communication.

NOTICE

RISK OF EQUIPMENT DAMAGE

Limit the RID wire length to less than 30 m (98 ft).

Failure to follow these instructions can result in equipment damage.

At some installations, a nearby lightning strike may induce a surge current in the RID wiring large enough to damage the internal circuit. Limiting the wire length will reduce this risk.

Dry Contact Output Connection

⚠ WARNING

HAZARD OF SHOCK. RISK OF EQUIPMENT DAMAGE.

Do not connect circuits exceeding 28 VDC and 3 A to the dry contact output. Use of a 3 A/32 VDC certified fuse is recommended.

Failure to follow these instructions can result in death, serious injury, or equipment damage.

One set of dry contact connections is provided to give a remote indication of inverter status. When the inverter is operating normally, the contact is closed. If the inverter is not operating, the contact is open.

For the location of the connection, see Figure 2-42.

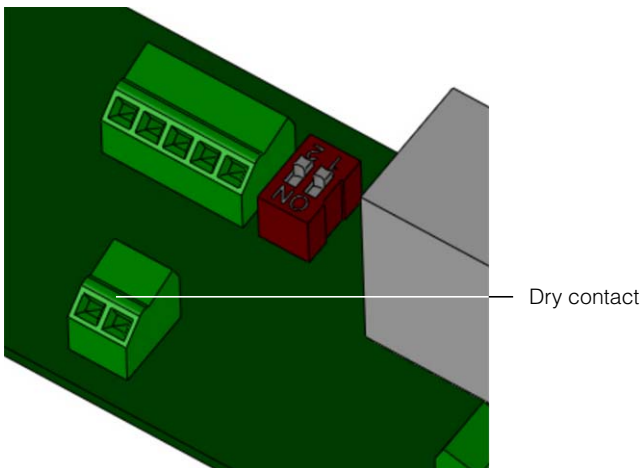

Figure 2-42 Dry contact location

Remote Monitoring Services

- Web Log: Data logger by MeteoControl. Connection via RS485.
- Solar Log: Data logger by Solare Datensysteme. Connection via RS485.

When MeteoControl and Solar log dataloggers are used, data is imported from the inverters via an RS485 interface. For more information refer to the operations instructions of the particular data logger.

Starting the Conext TL Inverters

Start up procedure:

1. Ensure that the external PV and AC disconnection means are de-energized before starting the inverter.
2. Make sure the AC wiring and DC wiring have been completed. See “AC Plug Wiring” on page 2–29 and “DC Wiring (From PV Array)” on page 2–37.
3. Make sure the cover of the communication module slot is back in place.
4. Replace the cover on the wiring box.
5. Ensure all the MC4 connectors are properly locked.
6. Turn ON the external AC and DC disconnect switches.
7. Turn the DC switch to the “ON” position. For the switch location, see Figure 1-8 on page 1–9.
8. Check the status of the indicator light (LED; see Table 3-2 on page 3–4). The LED should be solid green.
9. If the LED is not solid green, check that:
 - All the connections are correct.
 - All external disconnect switches are closed.
 - The DC switch of the inverter is in the “ON” position.

Navigating the LCD Menus and Screens

Use the four buttons below the LCD to navigate the LCD menus and screens, as shown in Table 2-10.

Table 2-10 Buttons below the LCD

Button	Result
ESC	Go to the previous screen.
▼	Go to the next item in a menu or to the next screen (in a series of screens).
▲	Go to the previous item in a menu or to the previous screen (in a series of screens).
OK	Executes the selected menu item, accepts the changes, or takes you to the next screen (in a series of screens).

Figure 2-43 shows an example of the effects of the buttons.

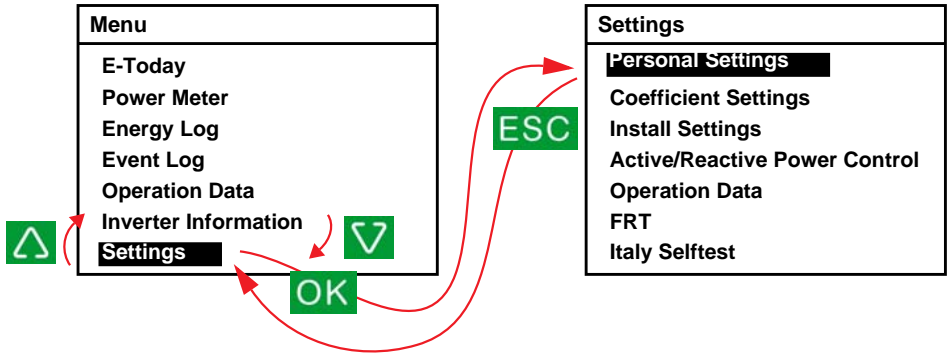

Figure 2-43 Navigating the LCD menus and screens

Selecting the Country

The first time the inverter is energized and turned on, the Select Country screen is displayed. The window is shown in Figure 2-44. (To display this screen at a later time, use the technician password to access the Install Settings menu, as described in “Install Settings Menu” on page 2-58, select **Country/Grid**, and then press OK. Select **Country/System**, and then press OK.)

NOTE: For information on specific approvals that the inverters have, see Appendix A, “Regulations and Directives” on page A-6.

▲ WARNING
<p>HAZARD OF ELECTRIC SHOCK</p> <ul style="list-style-type: none"> • The selected country code can only be changed by qualified personnel. • Ensure that local grid code selections are properly made before installing the inverter. <p>Failure to follow these instructions can result in death or serious injury.</p>

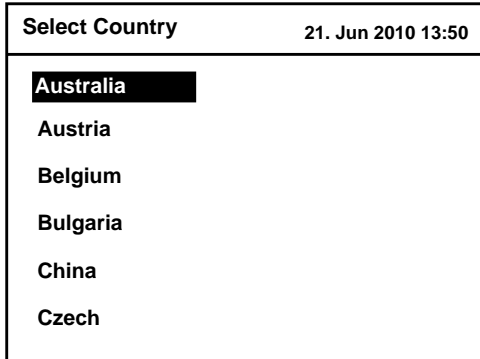

Figure 2-44 Select Country screen

The country selection sets specific parameters for protection and other features, according to country-specific requirements. For a listing of settings contained in each country selection, see Appendix C, "Country-Specific Settings".

To specify the country:

1. Use the ▼ and ▲ buttons to select the country, and then press OK.
 - Custom: Select this value if you want to change the Grid Setting. See "Grid Setting" on page 2-62.
2. In the Confirm Country screen, press OK to confirm your selection, or press ESC to go to the previous screen.
After you press OK, the Select Language screen is displayed.

Selecting the Language

In the Select Language screen you can specify what language is used in all of the screens, as shown in Figure 2-45.

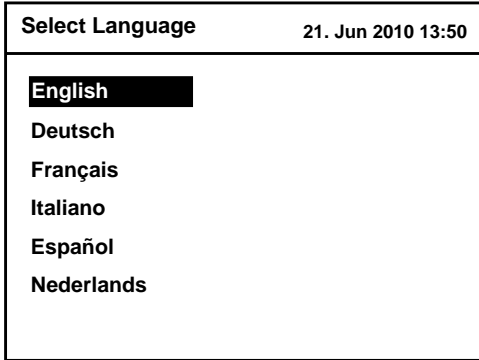

Figure 2-45 Select Language screen

To specify the language:

- ◆ Use the ▼ and ▲ buttons to select the language, and then press OK.

After you have set the language, the main menu is displayed in the selected language, as shown in Figure 2-46.

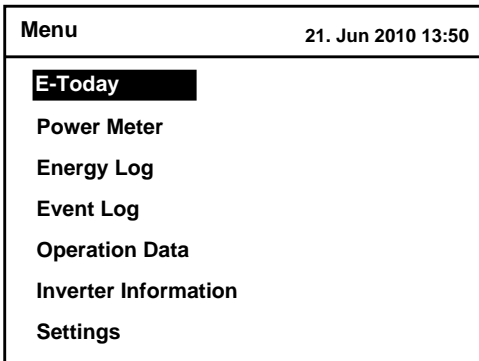

Figure 2-46 Main menu

Menu Structure

Figure 2-47 and Figure 2-48 show the items that are available from each menu.

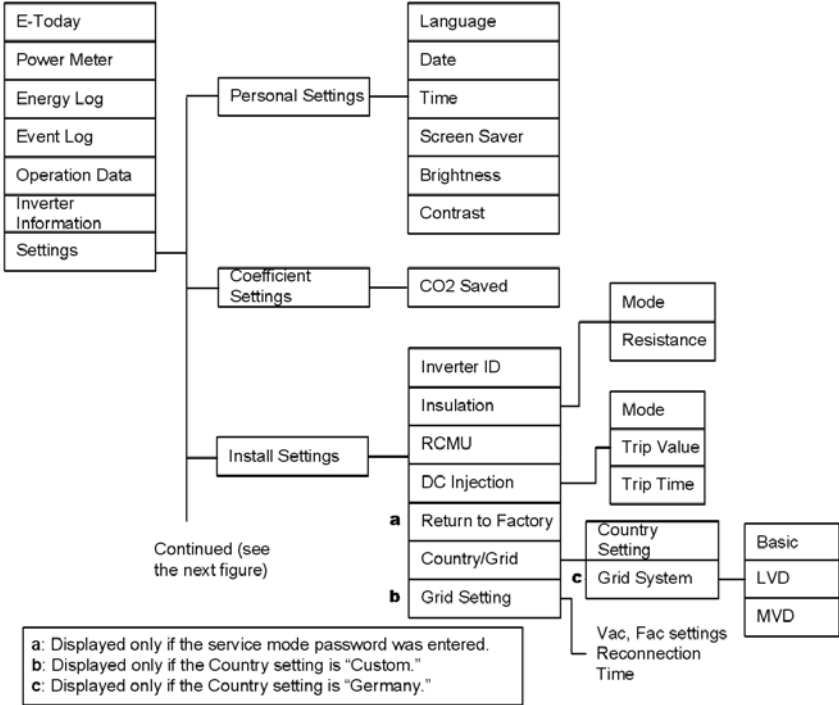

Figure 2-47 Main menu (figure 1 of 2)

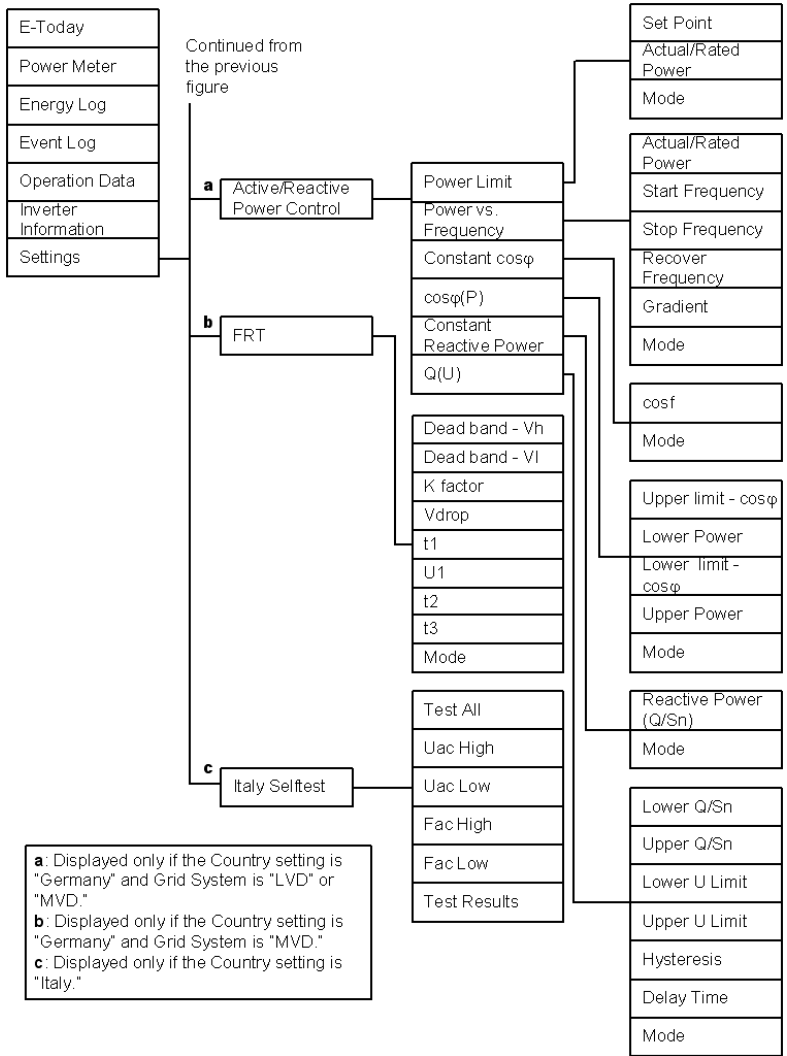

Figure 2-48 Main menu (figure 2 of 2)

Changing the Settings (Settings Menu)

From the Settings menu, adjust the following settings or perform these tests:

- Personal settings. See the next section, "Setting the Date and Time."
- Coefficients settings. See page 2–57.
- Install settings. See page 2–58.
- Active/reactive power control settings. See page 2–62.
- Low voltage ride through. See page 2–72.
- Italy selftest (available only if the Country setting is "Italy"; for more information, see "Selecting the Country" on page 2–52). For more information on Italy selftest, see page 2–76.

To view the Settings menu:

- ◆ From the main menu, select **Settings**, and then press OK.

Setting the Date and Time

To set the date and time:

1. Display the Settings menu as described above.
2. Select **Personal Settings**, and then press OK.
3. Use the ▼ button to select the Date, and then press OK.
4. Use the ▼ and ▲ buttons to adjust the date, month, and year; press OK to move from date to month to year. Once done, press OK.
5. Use the ▼ and ▲ buttons to adjust the time (hour and minutes). Once done, press OK.

Coefficient Settings Menu

From the Coefficient Settings menu, you can set the following:

- CO₂ Saved: Amount of CO₂ (in kg) generated when producing, from non-renewable energy sources, 1 kWh. This coefficient is used to approximate and display, in the Power Meter and Energy Log screens, the reduction of CO₂ production as a result of using the inverter.

To view the Coefficient Settings menu:

1. From the main menu, select **Settings**, and then press OK.
The Settings menu is displayed.
2. Select **Coefficient Settings**, and then press OK.

Install Settings Menu

▲ WARNING

HAZARD OF ELECTRIC SHOCK AND FIRE

Some settings available in the Install Settings menu and submenus are related to safety functions and must only be adjusted by authorized personnel aware of the impact of changing the settings, and only with the agreement of the local authority.

Failure to follow these instructions can result in death or serious injury.

From the Install Settings menu, you can configure these settings:

- Inverter ID: Used to distinguish each inverter if you have several of them installed.
- Insulation: See “Insulation Setting” on page 2–59.
- RCMU: See “RCMU Setting” on page 2–60.
- DC Injection: See “DC Injection Setting” on page 2–60.
- Return to Factory: See “Restoring the Inverter to its Default Settings” on page 2–77.
- Country/Grid: See “Grid System Setting” on page 2–61.
- Grid Setting: See “Grid Setting” on page 2–62.

To display the Install Settings menu:

1. From the main menu, select **Settings**, and then press OK.
2. Select **Install Settings**, and then press OK.
3. Use the ▼ and ▲ buttons to set each of the four digits in the password. Press OK after each digit is entered, and then press OK.
Two types of passwords are available:
 - Technician password: Gives access to some items that are hidden from the day-to-day user of the inverter.
 - Service mode: Gives access to all the items that are accessed using the technician password and additionally gives access to this menu item:
 - Return to Factory

If you require these access levels and do not know the passwords, contact Schneider Electric. The passwords will be provided only to qualified installers and service personnel.

Insulation Setting

The inverter uses an array-to-ground insulation resistance test to detect a ground fault in the array. You can set the test mode and resistance value. Whenever DC is not detected, and at least once a day, the inverter runs the test, using the specified settings.

To specify the insulation detection method:

1. Access the Install Settings menu, using the technician password. See “Install Settings Menu” on page 2-58.
2. Select **Insulation**, and then press OK.
3. From the Insulation menu, select a value for Mode, and then press OK.

Specify a value depending on the DC wiring conditions:

- **ON:** Enables the measurement of impedance between the PV array and PE. The inverter does not connect to the grid if this test fails.
- **DC1 Only:** Uses only DC1. See Figure 1-8 on page 1-9.
- **DC2 Only:** Uses only DC2. See Figure 1-8 on page 1-9.
- **Disable:** Disables the measurement of impedance between the PV array and PE.

WARNING

HAZARD OF FIRE

If you select “Disable” or incorrectly set “DC1 Only” or “DC2 Only”, you are turning off a fire prevention feature. You must provide external ground fault protection.

Failure to follow these instructions can result in death or serious injury.

4. From the Insulation menu, select the desired resistance value (default value is 1200 Kohms), and then press OK.

NOTE: Local PV installation codes may specify the minimum resistance value for this feature.

RCMU Setting

The RCMU setting enables the Residual Current Monitoring Unit, which shuts down the inverter if the residual current exceeds the sudden change or steady state thresholds (these values are not adjustable).

Residual Current refers to the leakage current to ground from the array during inverter operation. The RCMU detects two types of residual current event:

- Excessive steady-state residual current—detection of slowly changing current, to reduce fire hazard.
- Sudden change of residual current—fast detection to reduce shock hazard to personnel.

To specify the RCMU setting:

1. Access the Install Settings menu, using the technician password. See “Install Settings Menu” on page 2–58.
2. Select **RCMU**, and then press OK.
3. Select a value:
 - ON: The inverter shuts down if the residual current goes over either the steady state or sudden change limit.
 - OFF: The Residual Current Monitoring Unit does not monitor either limit.

▲ WARNING
HAZARD OF ELECTRIC SHOCK AND FIRE <ul style="list-style-type: none">• If you select “OFF”, you are turning off a shock and fire protection feature.• Do not select “OFF” without providing equivalent protection elsewhere in the system. Failure to follow these instructions can result in death or serious injury.

4. Press OK.

DC Injection Setting

The DC Injection setting specifies whether the inverter shuts down if the DC component in AC current goes over the limit.

To specify the DC Injection setting:

1. Access the Install Settings menu, using the service mode password. See “Install Settings Menu” on page 2–58.
2. Select **DC Injection**, and then press OK.
3. Select a value:
 - ON (default): The inverter shuts down if the DC component in AC current goes over the limit.

- OFF: The inverter does not shut down if the DC component in AC current goes over the limit.

⚠ WARNING

HAZARD OF ELECTRIC SHOCK AND FIRE

- If you select "OFF", you are turning off a shock and fire protection feature.
- Do not select "OFF" without providing equivalent protection elsewhere in the system.

Failure to follow these instructions can result in death or serious injury.

- Specify a value for Trip Value and Trip Time.
Valid range for Trip Value is 0.0 to 1.0 A. The default value is 0.7 A.
Valid range for Trip Time is 0.0 to 5.0 seconds. The default value is 0.2 seconds.
NOTE: Local grid interconnection codes may specify the maximum DC injection value and trip time for this feature.
- Press OK.

Grid System Setting

To specify the Grid System setting:

- Access the Install Settings menu, using the technician password. See "Install Settings Menu" on page 2-58.
- Select **Country/Grid**, and then press OK.
The Country/Grid screen is displayed.
- Select **Grid System**, and then press OK.
NOTE: The Grid System menu item is available only if the Country setting is "Germany." See "Selecting the Country" on page 2-52.
- Select the grid connection type:
 - Basic (VDE0126-1-1)
 - Low Voltage Directive (LVD). For settings that you can configure, see "Active/Reactive Power Menu" on page 2-62.
 - Medium Voltage Directive (MVD). For settings that you can configure, see "Active/Reactive Power Menu" on page 2-62 and "Low Voltage Ride Through" on page 2-72.

NOTE: The Active/Reactive Power menu (page 2-62) is available only if Grid System is "LVD" or "MVD."

Grid Setting

NOTE: The Grid Setting menu is available only if the Country setting is “Custom.” See “Selecting the Country” on page 2–52.

To specify the Grid Setting parameters:

1. Access the Install Settings menu, using the service mode password. See “Install Settings Menu” on page 2–58.
2. Select **Grid Setting**, and then press OK.

The following items can be set (over several screens):

- Vac High Off
- Vac High On
- Vac High Off T (disconnect time)
- Vac Low Off
- Vac Low On
- Vac Low Off T (disconnect time)
- Vac High Off Slow
- Vac High On Slow
- Vac High Off Slow T (disconnect time)
- Vac Low Off Slow
- Vac Low On Slow
- Vac Low Off Slow T (disconnect time)
- Fac High Off
- Fac High On
- Fac High Off T (disconnect time)
- Fac Low Off
- Fac Low On
- Fac Low Off T (disconnect time)
- Reconnect Time

Active/Reactive Power Menu

NOTE: The menu is available only if the country setting is “Germany LV”, “Germany MV”, “Italy BT” or “Italy MT”. For more information, see “Grid System Setting” on page 2–61.

A checkmark (✓) is displayed next to a menu item if the feature is enabled.

To display the Active/Reactive Power menu:

1. From the main menu, select **Settings**, and then press OK.
2. Select **Active/Reactive Power Control**, and then press OK.
3. Use the ▼ and ▲ buttons to enter each of the four digits in the password, and then press OK.

If you have entered the correct password, the Active/Reactive Power menu is shown.

Setting the Active Power Control

NOTE: Two options are available. Both can be enabled at the same time.

Setting the Power Limit

You can limit the output power of the inverter to a percentage of actual or rated power.

To set the power limit:

1. Display the **Active/Reactive Power** menu (see below).

Active/Reactive Power	21. Jun 2011 13:50
√ Power Limit	
√ Power vs. Frequency	

√ Constant $\cos\phi$	
√ $\cos\phi(P)$	
Constant Reactive Power	
Q(U)	

Figure 2-49 Power Limit

2. Select **Power Limit**, and then press OK.
3. In the Set Point field, use the ▼ and ▲ buttons to specify the percentage that you want to use as the limit. Valid range is 0 to 100%.
4. In the Actual/Rated Power field, select Rated or Actual.
If you select Actual, the current available power value is used as the value to which the percentage (specified by the Set Point field) is applied.
If you select Rated, the percentage is applied to the full rated output power of the inverter.
5. To enable the power limit, set the Mode field to ON.
6. To disable the power limit and to use MPP tracking, set the Mode field to OFF.

Setting the Frequency-Dependent Active Power Control

You can turn this feature on or off, and adjust the settings to meet the utility requirements.

To set the frequency-dependent active power control:

1. Display the **Active/Reactive Power** menu (see page 2–62).
2. Select **Power vs. Frequency**, and then press OK.
3. In the Active Power Control window, specify the desired frequencies and gradient. See Figure 2-51 on page 2–65.

Active Power Control		21. Jun 2010 13:50
	Actual/Rated Power	[Actual]
(A)	Start Frequency	[50.30] Hz
(B)	Stop Frequency *1	[-----] Hz
(C)	Recovery frequency *2	[-----] Hz
(D)	Gradient *3	[2.4] %
	Recovery Time*4	[300.00] s
	Mode	[ON] Hz

*1 It is the frequency of the zero power. The value of stop frequency is calculated by gradient.

For Italy BT/MT: Start frequency = Stop frequency + gradient x 50

*2 Recovery frequency value is equal to frequency of connection.

*3 If Country setting is Germany LV/MV, it means the slope of power xx%/Hz. If country setting is Italy BT/MT, it is used to calculate the frequency of zero power.

*4 Recovery time is the time where the inverter has to stay on the power if frequency comes back to normal till this time is up.

Figure 2-50 Active power control

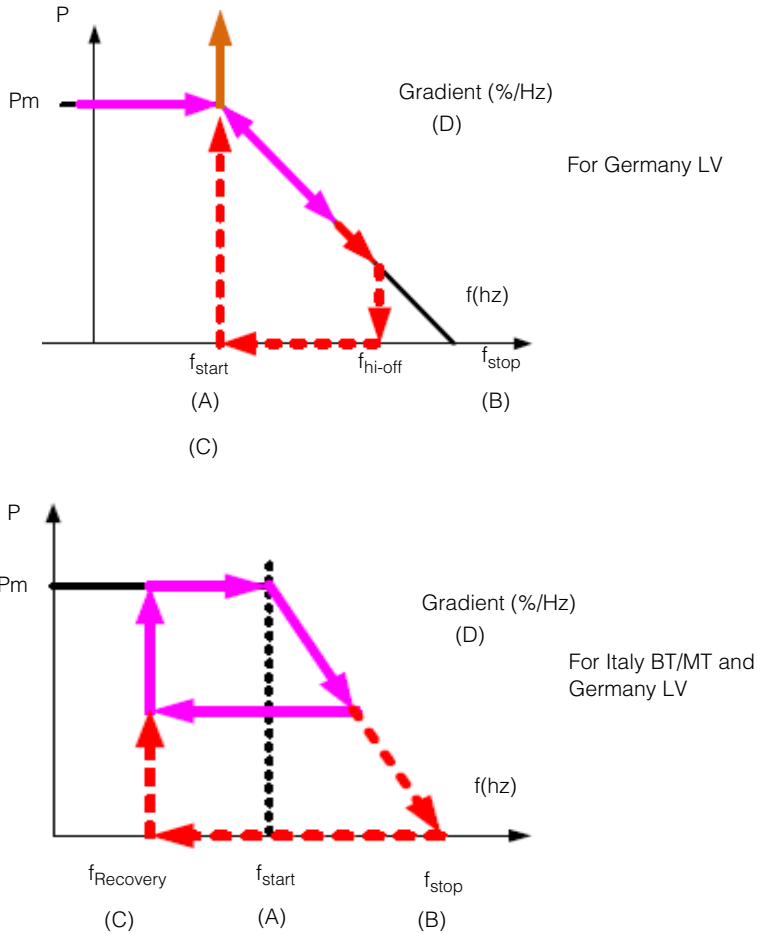

Figure 2-51 Frequency-dependent active power control

NOTE: See local grid interconnection codes for the need to turn this feature on or off, and the allowed values for each of the parameters shown in the above figures.

4. To enable the settings, set the Mode field to ON.

Setting the Reactive Power Control

Four methods of reactive power control are available.

NOTE: Only one of the four methods can be enabled at a time.

See local grid interconnection codes for the need to turn this feature on or off, the characteristic to select, and the allowed values for the various parameters.

The available methods are:

- Fixed power factor (constant $\cos\phi$). See below.
- Power factor as a function of active power ($\cos\phi(P)$). See below.
- Constant reactive power (Q). See page 2–69.
- Reactive power as a function of voltage (Q(U)). See page 2–70.

The inverter stops reactive power flow when the output power is below 10% of rated.

Setting the fixed power factor (Constant $\cos\phi$)

With this method, the inverter delivers reactive power determined by the available active power and the power factor you specify.

Reactive Power Control	21. Jun 2011 13:50
$\cos\phi$	[Ind 0.90]
Mode	[ON]

Figure 2-52 Fixed power factor

To set the fixed power factor (Constant $\cos\phi$):

1. Display the **Active/Reactive Power** menu (see page 2–62).
2. Select **Constant $\cos\phi$** , and then press OK.
3. In the $\cos\phi$ field, specify the value (from 0.8 capacitive to 0.8 inductive).
The adjustment resolution is 0.01.
4. To enable the fixed power factor (constant $\cos\phi$), set the Mode field to ON.

Setting a power factor as a function of active power ($\cos\phi(P)$)

With this method, the inverter delivers reactive power determined by the available active power and the power factor. The power factor varies, depending on the output active power at that moment. To set $\cos\phi(P)$:

Reactive Power Control	21. Jun 2010 13:50
Upper limit - $\cos\phi$	[Cap 0.80]
Lower Power	[0]%
Lower limit - $\cos\phi$	[Ind 0.80]
Upper Power	[100]%
Lock-in Voltage	[241.5]V
Reactive Power Control	21. Jun 2010 13:50
Lock-out Voltage	[230.0]V
Mode	[OFF]

Note: Lock-in and Lock-out voltage values are adjustable only if country setting is Italy BT/MT. It means the inverter would feed-in reactive power that depends on active power once grid voltage is higher than Lock-in voltage, and back to pure active power control when grid voltage is lower than Lock-out voltage. For countries other than Italy, $\cos\phi(P)$ control is not affected by grid voltage.

Figure 2-53 Power factor (Constant $\cos\phi$)

1. Display the **Active/Reactive Power** menu (see page 2–62).
2. Select **$\cos\phi(P)$** , and then press OK.
3. Specify the desired limits (upper and lower) for $\cos\phi$ and for power. See Figure 2-54 on page 2–68.

The adjustment resolution for $\cos\phi$ is 0.01.

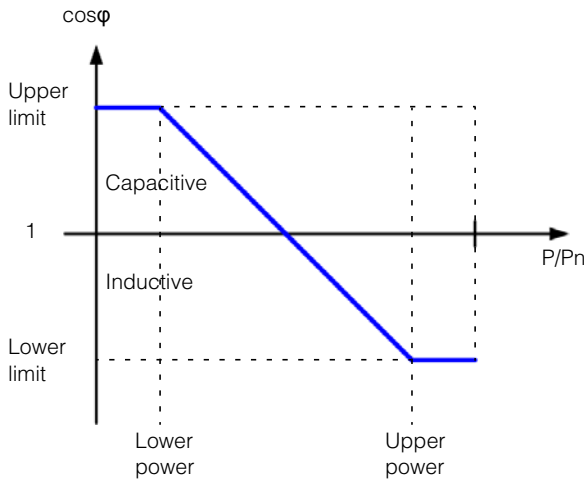
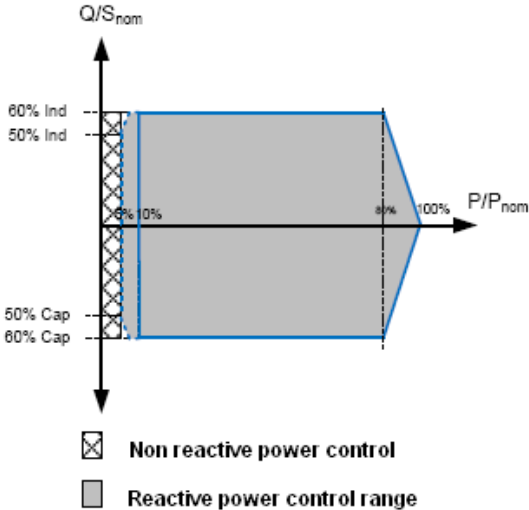

Figure 2-54 $\cos\phi(P)$

4. To enable the settings, set the Mode field to ON.

Setting Constant Reactive Power (Q)

With this method, the inverter delivers reactive power (Q) at a constant, specific level. As shown in Figure 2-55.



Note: The grey zone is the operation range of Constant Reactive Power Control. 5-10% is the hysteresis.

Figure 2-55 Constant Reactive Power (Q)

To set constant reactive power (Q):

1. Display the **Active/Reactive Power** menu (see page 2-62).
2. Select **Constant Reactive Power**, and then press OK.
3. In the Reactive Power (Q/Sn) field, select the desired setting. The valid range is Cap 53% ~ Ind 53%.
4. To enable constant reactive power, set the Mode field to ON.

Setting reactive power as a function of voltage (Q(U))

This setting allows the inverter to vary reactive power flow as a function of AC voltage.

NOTE: This item is available only when country setting is Germany LV, Germany MV, Italy BT or Italy MT. For more information, see "Grid System Setting" on page 2-61.

Q/Sn (%) has these characteristics:

- Cap 60% ~ Ind 60%
- Resolution is 1%
- U limit: 184 ~ 276 VAC (line to neutral)
- Response time: 0 ~ 60 s

To set reactive power as a function of voltage (Q(U)):

1. Display the **Active/Reactive Power** menu (see page 2-62).
2. Select **Q(U)**, and then press OK.
3. Specify the desired limits (upper and lower) of the ratio of reactive power (Var) to rated apparent power (VA) expressed as a percentage ("Q/Sn(%)"). This is the dependent variable of this function. The independent variable is the grid voltage ("U"). You can also specify the hysteresis and delay time. See Figure 2-55 on page 2-69.

The hysteresis can be between 3 and 20 V (resolution of 0.1 V).

The delay time can be between 10 and 60 seconds.

This inverter supports two operation curves of Q(U) control. Curve B is only for Italy BT or Italy MT.

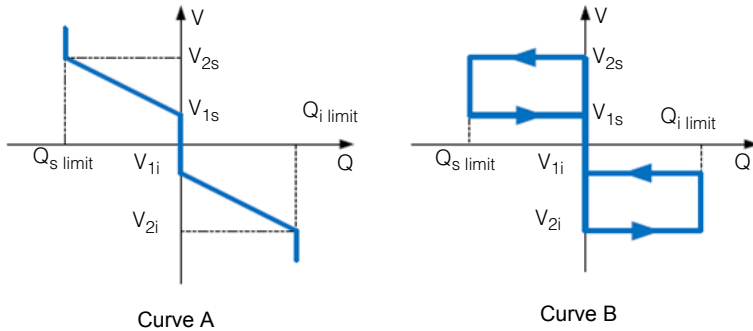

Reactive Power Control		21. Jun 2010 13:50
V _{1s}	[248.4]V	
V _{2s}	[253.0]V	
Q _{s limit}	[Ind 44]%	

V _{1i}	[211.6]V	
V _{2i}	[207.0]V	
Q _{i limit}	[Cap 44]%	
Reactive Power Control		21. Jun 2010 13:50
Delay Time	[10]s	
Lock-in Power *1	[20]%	
Lock-out Power *1	[5]%	
Mode *2	[OFF]%	

*1: Lock-in and Lock-out power are adjustable and enabled only if country setting is Italy BT or MT.

*2: Can be set as OFF, Curve A or Curve B, only Italy BT or Italy MT. Other countries can select only OFF or Curve A.

Figure 2-56 Voltage (Q(U))

- To enable Q(U), set the Mode field to ON.

Low Voltage Ride Through

NOTE: Low Voltage Ride Through (LVRT) is also known as Fault Ride Through (FRT), and refers to a feature that keeps the inverter online during short-duration voltage dips, to help support the grid.

From the FRT screen, you can set the following:

- Dead band - V_H : $1.1 * V_n$
- Dead band - V_L : $0.9 * V_n$
- K factor: Reactive current ratio during FRT.
- V_{drop} : If the grid voltage drops below this value, the inverter immediately trips.
- t1: If the grid voltage drops and does not come back to U1 within t1 seconds, the inverter trips.
- U1: $0.3 * V_n$
- t2: If the grid voltage drops and does not come back to $0.9 * V_n$ within t2 seconds, the inverter trips.
- t3: If the grid voltage drops and does not come back to $0.9 * V_n$ within t3 seconds, the inverter trips. The inverter might trip for a short time or for a long time.
- Mode: ON or OFF

NOTE: The screen is available only if the Country setting is "Germany" and Grid System (in Settings > Install Settings > Country/Grid) is "MVD."

To display the FRT screen:

1. From the main menu, select **Settings**, and then press OK.
2. Select **FRT**, and then press OK.

Figure 2-57 on page 2-73 and Figure 2-58 on page 2-74 show graphs related to LVRT.

FRT - 1/2			
(A)	Dead band - Vh	[+10]	%
(B)	Dead band - VI	[-10]	%
(C)	K factor	[2.0]	
	Vdrop	[5]	%
	t1	[150]	ms
	U1	[20]	%
	t2	[1.5]	s

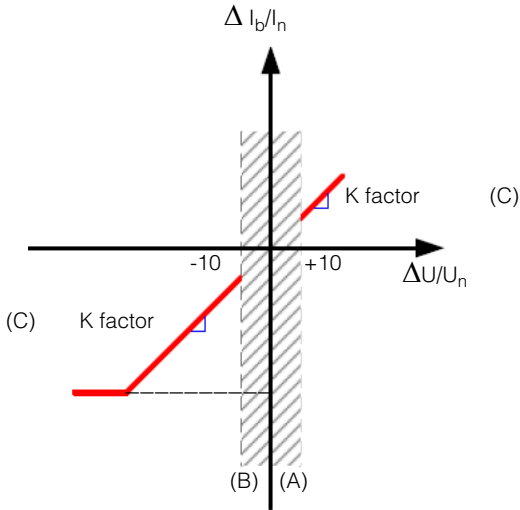

Figure 2-57 Low Voltage Ride Through (LVRT) (figure 1 of 2)

FRT - 1/2		
	Dead band - Vh	[+10] %
	Dead band - Vl	[-10] %
	K factor	[2.0]
(D)	Vdrop	[5] %
(E)	t1	[150] ms
(F)	U1	[20] %
(G)	t2	[1.5] s

FRT - 2/2		
(H)	t3	[3.0] s
	Mode	[ON] %

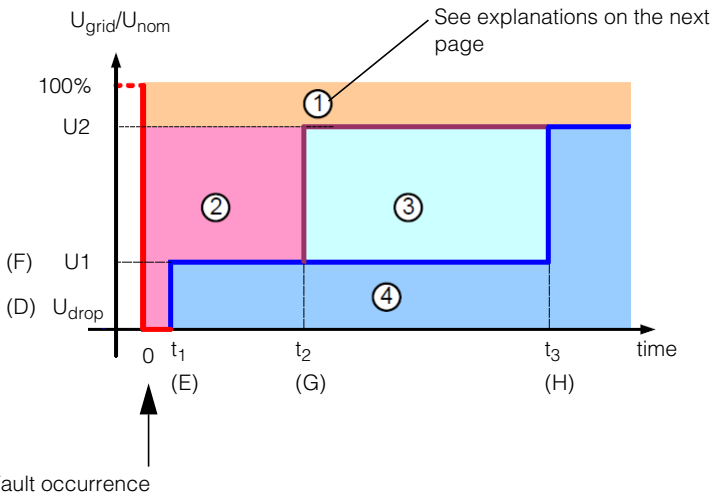

Figure 2-58 Low Voltage Ride Through (LVRT) (figure 2 of 2)

Additional information on the areas indicated by ①, ②, ③, and ④ in Figure 2-58 on page 2-74:

- ①: Does not lead to disconnection from network.
- ②: Pass through fault without disconnecting from network, feed in* short circuit current.
- ③: Short-term disconnect from network.
- ④: Disconnects from network.

*For Germany MV, feed-in is calculated reactive current. If the country setting is Italy BT or Italy MT, inverter would not feed in active or reactive current but will just stay connected.

For Country setting “Italy”

LVRT is available for CEI-021 and A70. This feature allows the FRT features to be set. Conext TL provides two settings for Italy (Italy LV and Italy MT).

Select Italy MV and LVRT settings are described below.

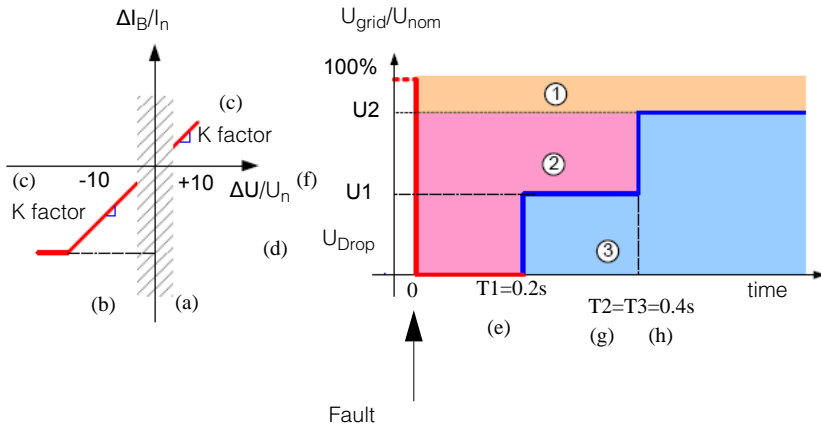

FRT -1/2		21. Jun 2010 13:50
(a)	Dead band - Vh	[+10]V
(b)	Dead band - Vl	[-15]V
(c)	K factor	[2.0]%
(d)	Vdrop	[0]V
(e)	t1	[200]V
(f)	U1	[40]%
(g)	t2	[0.4]%
FRT - 2/2		21. Jun 2010 13:50
(h)	t3	[0.4]s
(i)	Mode	[ON]%

Figure 2-59 Low Voltage Ride Through (LVRT) (figure 1 of 2)

Italy Selftest Menu

NOTE: This item is available only if the Country setting is “Italy.” For more information, see “Selecting the Country” on page 2–52.

It may take several minutes for a test to complete.

If any of the selftests listed below are not successful, this indicates that a required protection function is not working properly, and the inverter will no longer operate. Contact Schneider Electric customer service.

To display the Italy Selftest menu:

1. From the main menu, select **Settings**, and then press OK.
2. Select **Italy Selftest**, and then press OK.
3. Use the ▼ and ▲ buttons to select an option, and then press OK.
 - Test All: Executes all of the tests listed below, and displays the results on one screen.
 - Uac High: AC Voltage High
 - Uac Low: AC Voltage Low
 - Fac High: AC Frequency High
 - Fac Low: AC Frequency Low

Exiting Technician or Service Mode Level of Security Access

After you have finished the configuration, exit the technician or service mode level of security access to prevent others users from having access to password-protected menu items.

To exit the technician or service mode level of security access:

- ◆ Press the ESC button to go up one level in the menu structure, until the main menu is shown.

Restoring the Inverter to its Default Settings

To delete all records of events (logs) and energy and restore the inverter to its default settings:

1. From the main menu, select **Settings**, and then press OK.
2. Select **Install Settings**, and then press OK.
3. Use the ▼ and ▲ buttons to enter each of the four digits in the service mode password, and then press OK.
4. Select **Return to Factory**, and then press OK.
5. Select **Yes**, and then press OK.

FRT settings for PO12.3 (Spain) on display

The Fault Ride Through settings for Spain is required for the units to be installed in medium voltage PV plants and shall conform to PO12.3 standards. The curves as per PO12.3 are shown in Figure 2-60 along with the display settings.

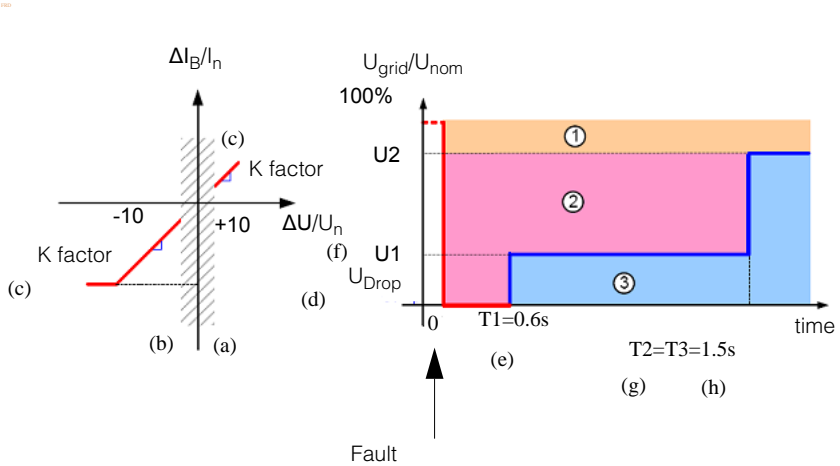

FRT -1/2		21. Jun 2010 13:50
(a)	Dead band - Vh	[+10]V
(b)	Dead band - Vl	[-15]V
(c)	K factor	[2.0]%
(d)	Vdrop	[0]V
(e)	t1	[600]V
(f)	U1	[20]%
(g)	t2	[1.5]%

FRT - 2/2		21. Jun 2010 13:50
(h)	t3	[1.5]s
(i)	Mode	[OFF]% RD1699 = OFF PO12.3 = ON

Figure 2-60 FRD settings for Spain

3

Operation

Chapter 3, “Operation” contains information on the basic operation of the inverter.

Turning the Inverter On

To turn the inverter on:

- ◆ Turn the DC switch to the “ON” position.

When there is sufficient sunlight, the inverter starts normal operation after a power-on self-test, which takes several minutes. If the LCD displays an error message, see “Troubleshooting” on page 4–1.

LCD and Control Panel

The inverter has an LCD and control panel, shown in Figure 3-1. Their locations are shown in Figure 1-4 on page 1–6.

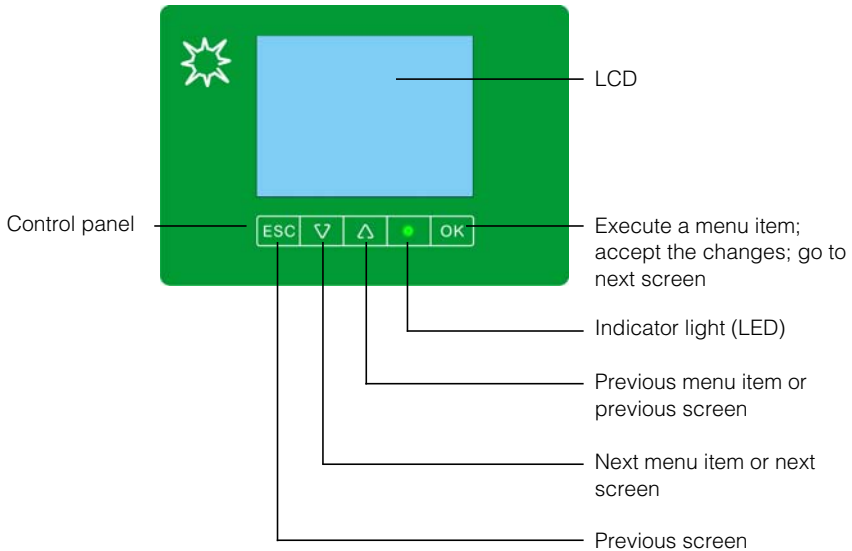

Figure 3-1 LCD and control panel

Navigating the LCD Menus and Screens

Use the four buttons below the LCD to navigate the LCD menus and screens, as shown in Table 3-1 on page 3-3.

If you press any of these buttons from the home page (“E-Today”), the main menu is displayed. See “Home Page (E-Today)” on page 3-4 and “Main Menu” on page 3-5.

Table 3-1 Buttons below the LCD

Button	Result
ESC	Go to the previous screen.
▼	Go to the next item in a menu or to the next screen (in a series of screens).
▲	Go to the previous item in a menu or to the previous screen (in a series of screens).
OK	Executes the selected menu item, accepts the changes, or takes you to the next screen (in a series of screens).

Figure 3-2 shows an example of the effects of the buttons.

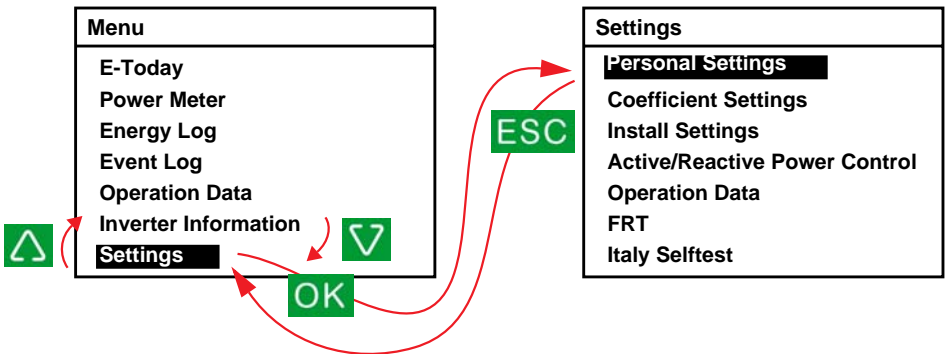

Figure 3-2 Navigating the LCD menus and screens

Indicator Light

Below the LCD is the indicator light (LED), which indicates the inverter status, as shown in Table 3-2.

Table 3-2 Indicator light

State of indicator light	Inverter status
Green, flashing ^a	Standby or countdown.
Green, solid	Power on.
Red, solid	Error or fault detected. Check the LCD for the message. See Table 4-1 on page 4-2.
Off	Night time (no DC).

a. Cycling on for one second, and then off for one second.

Home Page (E-Today)

When the inverter is operating normally, the LCD shows the home page as shown in Figure 3-3 on page 3-4. The home page shows:

- Energy harvested today (“E-Today”)
- The current date and time
- Run time for today
- Output power (“Power:”)
- Status of the inverter (for example, “On Grid”)
- Today’s power curve

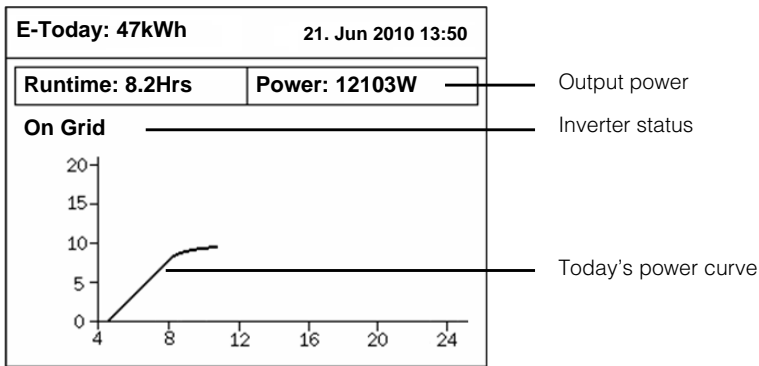

Figure 3-3 Home page (E-Today)

From the home page, if you press any of the four buttons below the LCD, the main menu is displayed.

Main Menu

From the main menu you can display the home page (E-Today), view various reports and logs, and access other menus.

To display the main menu:

- When the LCD shows the home page (see Figure 3-3), press any of the four buttons below the LCD.
- From any screen or menu, press the ESC button to go to the previous screen or higher-level menu, until the main menu is shown.

Figure 3-4 on page 3-5 shows the main menu.

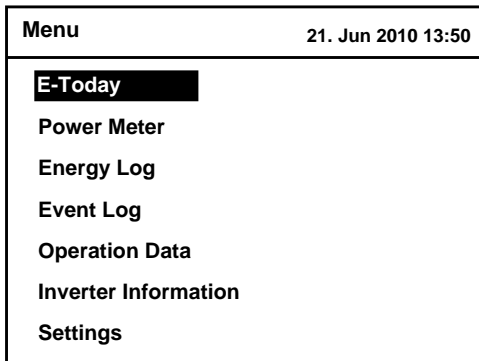

Figure 3-4 Main menu

Menu Structure

Figure 3-5 shows the items that are available from each menu.

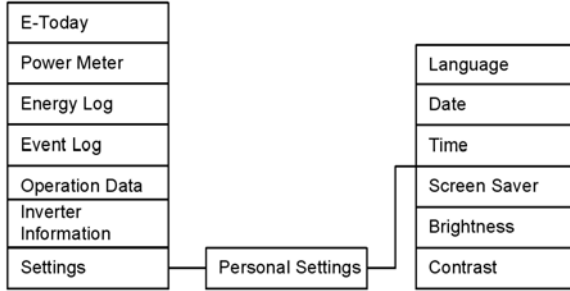

Figure 3-5 Menu organization

Selecting a Language

The language setting specifies the language used in the screens. You can specify the language in the Select Language screen.

To specify the language:

1. From the main menu, select **Settings**, and then press OK.
2. Select **Personal Settings**, and then press OK.
3. Select **Language**, and then press OK.
4. Use the ▼ and ▲ buttons to select the language, and then press ESC.

Viewing Performance Values

You can view present values and accumulated highest values (over the lifetime of the inverter).

Power Meter

From the Power Meter screens, you can view DC input, AC output, total power, and frequency.

To view the Power Meter screens:

1. From the main menu, select **Power Meter**, and then press OK.
2. To navigate through the Power Meter screens, press OK.
 The first screen shows P, U, and I values for MPP tracker 1 ("Input1") and MPP tracker 2 ("Input2").
 The second screen shows the values for AC output, total power, and frequency.
 The third screen shows the amount of electricity generated today and today's runtime.
3. To return to the main menu, press ESC from any screen.

Operation Data

From the Operation Data screens, you can view the current values of the:

- Maximum DC input (voltage, current, and power).
- Maximum AC output (voltage, current, and power).
- Maximum and minimum temperature inside the inverter.

To view the operation data:

1. From the main menu, select **Operation Data**, and then press OK. The first of four screens is displayed.
2. To go to the next screen, press the ▼ button or press OK. To go to the previous screen, press the ▲ button.

To clear the data:

1. Display any of the Operation Data screens (described above).
2. Press and hold the ▼ and ▲ buttons.
3. Without releasing the ▼ and ▲ buttons, press and hold the OK button. Hold all three buttons for at least 3 seconds.

Logs

You can view power generation logs and event logs.

Viewing Power Generation Logs (“Energy Log”)

From the Energy Log screen, you can view or clear data for power generation over the current or last year, month, and day.

To view the power generation logs:

1. From the main menu, select **Energy Log**, and then press OK. A summary screen (“Energy Log - Total”) is displayed.
2. To view graphs of power generation for the current time period, press OK. Each OK button press displays a graph for a different time period—the current year, month, or day.
To display a graph for the previous time period (for example, last year), press the ▼ button. To return to the graph of the current time period (this year, in our example), press the ▲ button.
3. To return to the summary screen (“Energy Log - Total”), press ESC.
4. From the summary screen, press ESC to return to the main menu.

To clear the power generation logs:

1. Display the Energy Log - Total screen (described above).
2. Press and hold the ▼ and ▲ buttons.
3. Without releasing the ▼ and ▲ buttons, press and hold the OK button. Hold all three buttons for at least 3 seconds.
4. Check the Energy Log screens (year, month, day) to verify that the logs have been cleared (the values should be 0).

Event Log

The event log shows 30 of the most recent events (errors or faults). The most recent event is shown at the top of the list.

To view the Event Log screens:

1. From the main menu, select **Event Log**, and then press OK.
The Event Log screen is shown.
2. Press OK to view the Event Summary screen, which displays a count for each type of event that occurred.
3. To return to the previous screen, press ESC.

To clear the event log:

1. Display the Event Log or Event Summary screen (described above).
2. Press and hold the ▼ and ▲ buttons.
3. Without releasing the ▼ and ▲ buttons, press and hold the OK button. Hold all three buttons for at least 3 seconds.

Inverter Information

The Inverter Information screen displays the following information about the inverter:

- Serial number
- DSP-Version: Firmware version
- Red.-Version: Redundant firmware version
- Comm.-Version: Version of communication software
- Installation date
- Inverter ID

To view the Inverter Information screen:

- ◆ From the main menu, select **Inverter Information**, and then press OK.

Changing the Settings (Settings Menu)

From the Settings menu, you can adjust the following settings:

- Personal settings. (See below.)

To view the Settings menu:

- ◆ From the main menu, select **Settings**, and then press OK.

Personal Settings Menu

From the Personal Settings menu, you can set the following:

- Language
- Date and the date format
- Time
- Screen saver (between 5 and 60 minutes): Specifies the amount of time, after which the LCD goes dim. (To restore the LCD brightness, press any button.)
- LCD brightness: A value from 1 (low) to 5 (high)
- LCD contrast: A value from 1 (low) to 5 (high)

To view the Personal Settings menu:

1. From the main menu, select **Settings**, and then press OK.
The Settings menu is displayed.
2. Select **Personal Settings**, and then press OK.

4

Troubleshooting

Chapter 4, “Troubleshooting” describes the error messages that might be displayed on the LCD of the inverter and recommended solutions.

Messages

Table 4-1 describes alert messages that might be displayed on the LCD of the inverter.

NOTE: The third column ("Number") refers to the alert code that can be read from the Modbus communications.

Table 4-1 Alert message descriptions

Message	Description and Solution	Number
No Alarm	No active alarms	0000
AC Switch Response	Relay open <ul style="list-style-type: none"> Contact Schneider Electric customer service. 	0010
Current Sensor	CT current sensor Event_A, Event_B, or Event_C <ul style="list-style-type: none"> Contact Schneider Electric customer service. 	0031
Thermal Sensor 1	Heat sink NTC 1 circuit fail <ul style="list-style-type: none"> Contact Schneider Electric customer service. 	0032
Thermal Condition (LTP)	Low temperature protection. After the inverter temperature returns to normal, the inverter resumes normal operation.	0080
Thermal Condition (OTP)	Over-temperature protection. After the inverter temperature returns to normal, the inverter resumes normal operation. <ul style="list-style-type: none"> Verify the air inlet and/or outlets are free of objects. Verify the inverter is not exposed to direct sunlight. 	0084
HW COMM2	An internal communication service interruption has occurred <ul style="list-style-type: none"> If the error persists for more than a few hours, contact Schneider Electric customer service. 	0095
Thermal Sensor 2	Heat sink NTC 2 circuit fail <ul style="list-style-type: none"> Contact Schneider Electric customer service. 	0103

Table 4-1 Alert message descriptions (Continued)

Message	Description and Solution	Number
Thermal Sensor 3	Heat sink NTC 3 circuit fail <ul style="list-style-type: none"> • Contact Schneider Electric customer service. 	0104
Thermal Sensor 4	Heat sink NTC 4 circuit fail <ul style="list-style-type: none"> • Contact Schneider Electric customer service. 	0105
Analog Input Bias 1	DSP ADC Vgrid/Iout bias fail. (The current and voltage values Vgrid/Iout (of the digital signal processor of the analog-to-digital converter) have deviated from reference values.) <ul style="list-style-type: none"> • Contact Schneider Electric customer service. 	0120
Analog Input Bias 2	DSP ADC Vin/Vbus bias fail. (The voltage input values Vin/Vbus (of the digital signal processor of the analog-to-digital converter) have deviated from reference values.) <ul style="list-style-type: none"> • Contact Schneider Electric customer service. 	0121
Analog Input Bias 3	DSP ADC Iin/Iboost bias fail. (The current input values Iin/Iboost (of the digital signal processor of the analog-to-digital converter) have deviated from reference values.) <ul style="list-style-type: none"> • Contact Schneider Electric customer service. 	0122
Analog Input Bias 4	Redundant ADC Vgrid/Vinv bias fail. (The voltage values Vgrid/Vinv (of the redundant analog-to-digital converter) have deviated from reference values.) <ul style="list-style-type: none"> • Contact Schneider Electric customer service. 	0123
Analog Input Bias 5	Redundant ADC Iout_dc bias fail. (The current value Iout_dc (of the redundant analog-to-digital converter) has deviated from reference values.) <ul style="list-style-type: none"> • Contact Schneider Electric customer service. 	0124

Table 4-1 Alert message descriptions (Continued)

Message	Description and Solution	Number
HW Efficiency	Efficiency abnormal <ul style="list-style-type: none"> • Contact Schneider Electric customer service. 	0130
RCMU Fault	The RCMU has failed its self-test and is not working properly, so it has disabled the inverter. For information on RCMU, see “RCMU Setting” on page 2-60. <ul style="list-style-type: none"> • Contact Schneider Electric customer service. 	0140
Relay Test S/C	Relay test short <ul style="list-style-type: none"> • Contact Schneider Electric customer service. 	0150
Relay Test O/C	Relay test open <ul style="list-style-type: none"> • Contact Schneider Electric customer service. 	0151
HW ZC Fail	Zero cross circuit fail <ul style="list-style-type: none"> • Contact Schneider Electric. 	0160
HW COMM1	Internal communication service interruption has occurred <ul style="list-style-type: none"> • If the error persists for more than a few hours, contact Schneider Electric customer service. 	0195
AC Current High	Output current exceeds the rated value. <ul style="list-style-type: none"> • If the error occurs frequently, contact Schneider Electric customer service. 	0460
AC Over Current	HW OSCP (Output Over Current Protection) circuit <ul style="list-style-type: none"> • If the error occurs frequently, contact Schneider Electric customer service. 	0461

Table 4-1 Alert message descriptions (Continued)

Message	Description and Solution	Number
Overvoltage DC	<p>Bus voltage, Bus Positive, or Bus Negative over voltage rating</p> <ul style="list-style-type: none"> • Have a qualified installer verify the PV array installation is correct. • Have a qualified installer check whether DC wiring is done according to this manual. • Contact Schneider Electric customer service. 	0601
DC Over current	<p>PV1 current, PV2 current, PV1 current transient, or PV2 current transient over rating</p> <ul style="list-style-type: none"> • Contact Schneider Electric customer service. 	0620
Bus Unbalance	<p>Bus unbalance</p> <ul style="list-style-type: none"> • Have a qualified installer check whether DC wiring is done according to this manual. • Contact Schneider Electric customer service. 	0650
DC Injection	<p>DC Injection Phase A, DC Injection Phase B, or DC Injection Phase C</p> <ul style="list-style-type: none"> • If the error occurs frequently, contact Schneider Electric customer service. 	0701
Ground Current High	<p>RCMU tripped. Excessive steady-state residual current or sudden change in residual current. For information on RCMU, see "RCMU Setting" on page 2–60.</p> <ul style="list-style-type: none"> • Have a qualified installer check the PV array for ground faults. • If the error occurs frequently, contact Schneider Electric customer service. 	0702
HW Connect Fail	<p>No connection to AC grid</p> <ul style="list-style-type: none"> • Have a qualified installer verify the AC plug connection and AC wiring are correct. 	2110

Table 4-1 Alert message descriptions (Continued)

Message	Description and Solution	Number
AC Freq Low	<p>Under frequency range</p> <p>Some of the parameters of the grid are temporarily out of normal range. After the parameters return to normal, the inverter resumes normal operation; the green LED is solid.</p> <ul style="list-style-type: none"> • Wait for the inverter to resume power production. 	2401
AC Freq High	<p>Over frequency range</p> <p>Some of the parameters of the grid are temporarily out of normal range. After the parameters return to normal, the inverter resumes normal operation.</p> <ul style="list-style-type: none"> • Wait for the inverter to resume power production. 	2402
AC Volt Low	<p>Under Voltage error</p> <p>Some of the parameters of the grid are temporarily out of normal range. After the parameters return to normal, the inverter resumes normal operation.</p> <ul style="list-style-type: none"> • Wait for the inverter to resume power production. 	2406
AC Volt High	<p>Slow Over Voltage Range error</p> <p>Some of the parameters of the grid are temporarily out of normal range. After the parameters return to normal, the inverter resumes normal operation.</p> <ul style="list-style-type: none"> • Wait for the inverter to resume power production. 	2407

Table 4-1 Alert message descriptions (Continued)

Message	Description and Solution	Number
Grid Quality	<p>Voltage Total Harmonic Distortion is > 3%</p> <p>Some of the parameters of the grid are temporarily out of normal range. After the parameters return to normal, the inverter resumes normal operation.</p> <ul style="list-style-type: none"> • Wait for the inverter to resume power production. 	2440
No Grid	<p>Grid voltage or frequency is out of range or not present at all</p> <ul style="list-style-type: none"> • If this message persists, have a qualified installer verify the AC plug connection and AC wiring are correct. 	2450
PV Voltage High	<p>String1 or String 2 PV input voltage too high</p> <ul style="list-style-type: none"> • Have a qualified installer verify the PV array voltage is within the allowed specifications for the inverter. 	2606
Isolation Impedance Error	<p>Array impedance to ground in either input is below the Insulation test set point (default value 1200 kOhms)</p> <ul style="list-style-type: none"> • Have a qualified installer check the PV array for ground faults. 	2616
Fan Rotation	<p>Fan warning. Possible reasons:</p> <ul style="list-style-type: none"> • One or more fans are defective. (Have a qualified installer replace the fan bracket, as described in "Semi-Annual Maintenance" on page 5-3.) • One or more fans are disconnected. (See "Periodic Maintenance" on page 5-2 before checking the fan connections. See Figure 5-4 on page 5-5.) 	4005
PV OC Voltage Low	<p>The input voltage of DC1 or DC2 is below the threshold to produce power. This occurs, for example, during the night, during snow storms, and during a total solar eclipse.</p>	6627

5

Preventive Maintenance

Chapter 5, “Preventive Maintenance” contains information and procedures for performing preventive maintenance on the inverter.

Periodic Maintenance

DANGER

HAZARD OF ELECTRIC SHOCK AND FIRE

- All electrical work must be done in accordance with local electrical codes.
- The Conext TL inverter has no user serviceable parts inside. To be installed and serviced only by qualified personnel equipped with appropriate PPE and following safe electrical work practices.
- Before installation, de-energize the AC and PV sources using external disconnecting means provided in the installation, and test using a meter rated at least 1000 V AC and DC to make sure all circuits are de-energized. If possible, follow a lock-out tag-out procedure.
- Do not connect PV conductors until the inverter is earthed either through the AC connection or through the earthing terminal.

Failure to follow these instructions will result in death or serious injury.

The term “qualified personnel” is defined on page iii of this manual. Personnel must be equipped with appropriate PPE and follow safe electrical work practices. The inverter is energized from the AC grid and up to four PV circuits. Before servicing the inverter or accessing the communication module, disconnect all sources and wait at least 1 minute to allow internal circuits to discharge. Operating the RID (Remote Inverter Disable) circuit or the switch on the inverter does not remove all power from the inverter. Internal parts and the external wiring remain live unless the PV and AC circuits have been disconnected externally.

To ensure reliable operation of the inverter, a semi-annual maintenance cycle is recommended.

This schedule is based on less-than-severe environment site conditions. For sites with blowing dust or other particulate matter or for sites subject to temperature extremes, you might need to increase the frequency of the maintenance cycle.

NOTE: Only use original spare parts provided by the manufacturer. Use of non-original parts invalidates the warranty.

For problems associated with the inverter, contact Schneider Electric.

Semi-Annual Maintenance

Have qualified personnel (as defined on page iii) perform the following semi-annual maintenance:

1. Visually inspect all conductors and connectors at the bottom of the inverter for signs of corrosion or overheating.
2. Check that all the connectors, screws, and cables are connected properly and are tightened to the proper torque specified in this manual.
3. If there are any defective parts (for example, the communication module or one of the fans is not working), contact Schneider Electric.
4. Clean the fans:
 - a) Loosen the four screws of the fan bracket (one screw at each of the corners of the bracket, as shown by the arrows in Figure 5-1 on page 5–3 and Figure 5-2 on page 5–4).

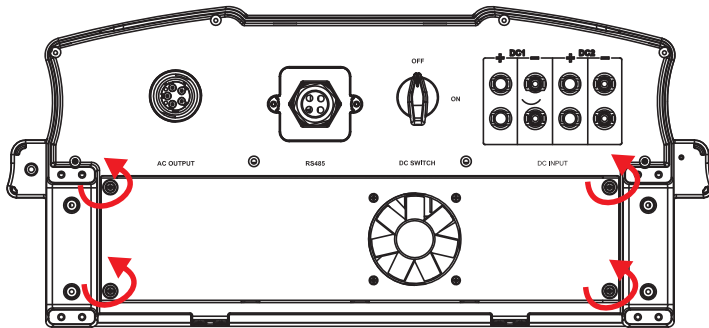

Figure 5-1 Loosening the screws of the fan bracket Conext TL 8000 E and Conext TL 10000 E models

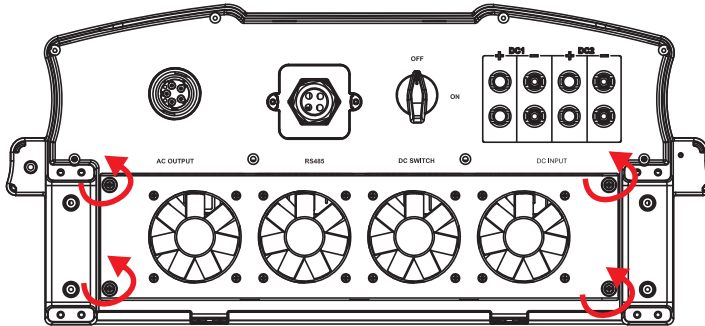

Figure 5-2 Loosening the screws of the fan bracket Conext TL 15000 E and Conext TL 20000 E models

- b) Pull the fan bracket slightly, to view the connector of the single fan in the Conext TL 8000E and Conext TL 10000 E, or each of the four fans in the Conext TL 15000 E and Conext TL 20000 E.
- c) Disconnect the connector for the fan(s). Figure 5-4 shows the first fan being disconnected.

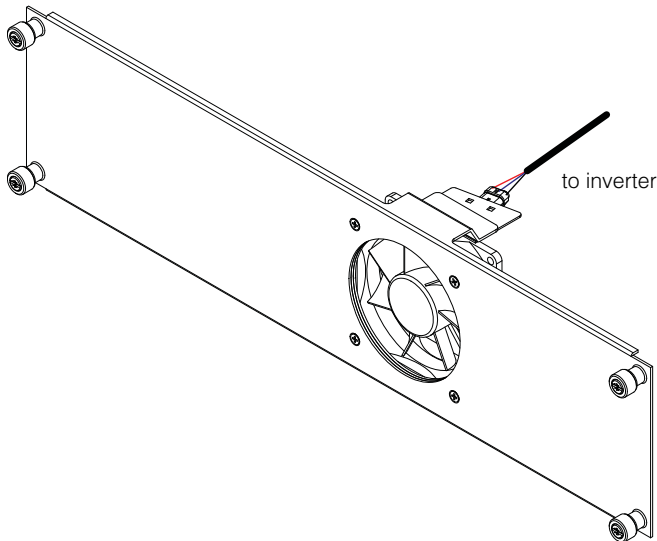

Figure 5-3 Disconnecting the fan connectors Conext TL 8000 E and Conext TL 10000 E models

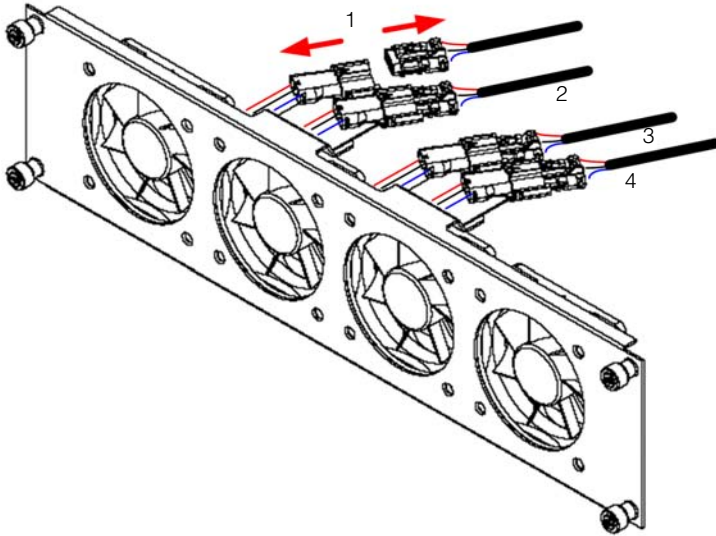

Figure 5-4 Disconnecting the fan connectors Conext TL15000 E and Conext TL 20000 E models

- d) Repeat step c for the three remaining fans in the Conext TL 15000E and Conext TL 20000E.
- e) Remove the fan bracket from the inverter, as shown in Figure 5-5 and Figure 5-6.

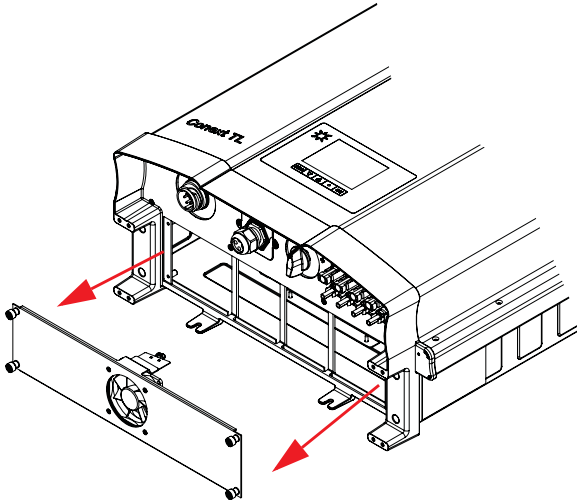

Figure 5-5 Removing the fan bracket Conext TL 8000 E and Conext TL 10000 E models

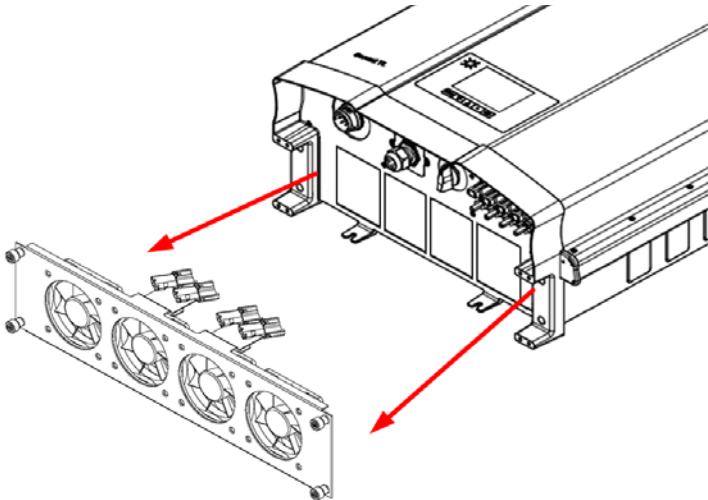

Figure 5-6 Removing the fan bracket Conext TL15000 E and Conext TL 20000 E models

- f) Use a clean, dry rag or brush to clean the fans.

NOTICE**RISK OF EQUIPMENT DAMAGE**

Do not use liquids (for example, water) or compressed air to clean the fans.

Failure to follow these instructions can result in equipment damage.

- g) If any fan has failed, replace the entire fan bracket.
 - h) Reconnect the fan connector(s).
 - i) Install the fan bracket onto the inverter.
 - j) Tighten each of the four screws of the fan bracket to 1.0 Nm. Their location is shown in Figure 5-1 on page 5-3 and Figure 5-2 on page 5-4.
5. Clean the two air outlets:
- a) Disassemble the four screws of each of the two air outlet covers, as shown by the circles in Figure 5-7 on page 5-7 and Figure 5-8 on page 5-8.

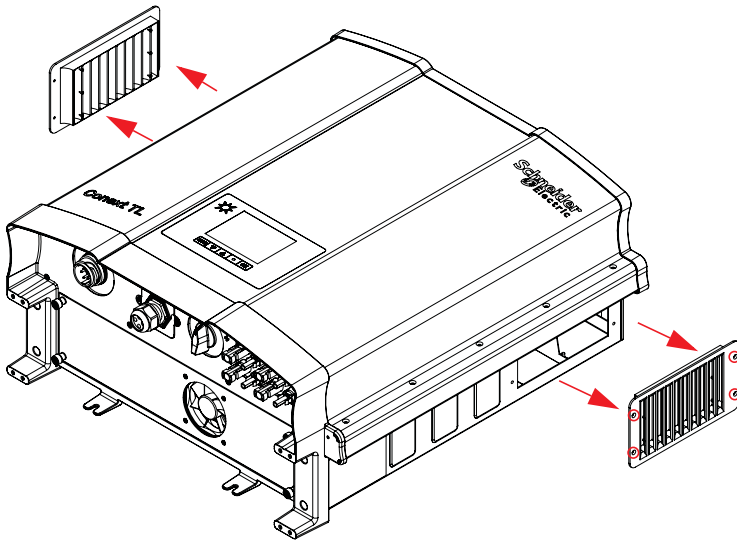

Figure 5-7 Removing the air outlet covers Conext TL 8000 E and Conext TL 10000 E models

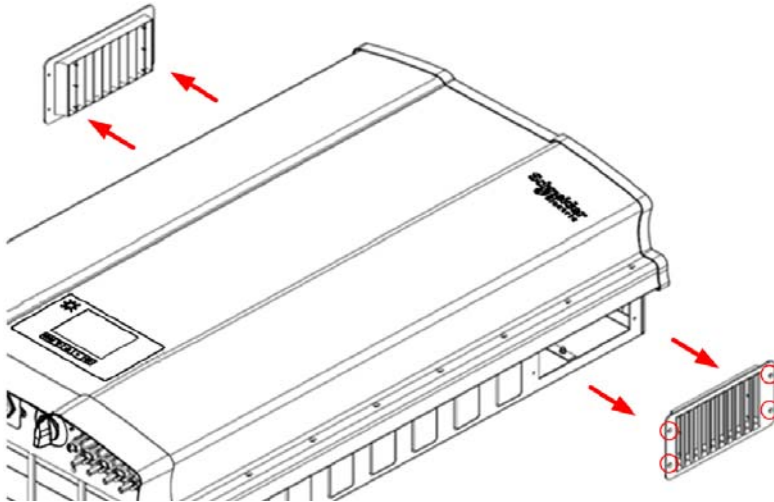

Figure 5-8 Removing the air outlet covers Conext TL15000 E and Conext TL 20000 E models

- b) Remove the covers, as shown by the arrows in Figure 5-7 and Figure 5-8.
- c) Remove any dust or objects.

<i>NOTICE</i>
RISK OF EQUIPMENT DAMAGE Do not drop any objects into the air outlet openings. Failure to follow these instructions can result in equipment damage.

- d) Using the screws, reattach the covers to the air outlets. Tighten each screw to 0.8 ± 0.2 Nm.

A

Specifications

Appendix A provides the environmental, electrical, and other specifications for the inverters.

NOTE: Specifications are subject to change without notice.

System Specifications

Environmental Specifications

Table A-1 Environmental specifications

Specification	Description
Operation altitude	< 2000 m (6561.6 ft.)
Enclosure	Powder coated aluminium. Color: RAL 9003.
Storage temperature	-25 to +65 °C (-13 to 149 °F)
Operating temperature	-20 to 60 °C (-4 to 140 °F), full power up to 40 °C (104 °F)
Environmental category	Outdoor, wet locations
Pollution degree	PD3
Protection degree	IP65 (electronics) IP55 (balance of the enclosure)
Relative humidity	4-100% condensing
Galvanic isolation	No electrical isolation between AC grid and PV. Dry contacts, RID (Remote Inverter Disable), and RS485 signal lines are protectively separated from PV and AC circuits.
Safety class	Class I metal enclosure with protective earth
Overvoltage category	Category III
Weight	41 kg (90.2 lb) for 8 kVA and 10 kVA, 67.2 kg (148.2 lbs) for 15 & 20 kVA
Dimensions	625 x 612 x 278 mm (24.6 x 24.1 x 10.9 in.) for 8 & 10 kVA 960 x 612 x 278 mm (37.8 x 24.1 x 10.9 in.) for 15 & 20 kVA
Connectors	Weather-resistant AC and DC connectors

Electrical Specifications

Table A-2 Electrical specifications

Parameter	Conext TL 8000 E	Conext TL 10000 E	Conext TL 15000 E	Conext TL 20000 E
DC (PV) input				
Nominal input power for maximum output	8.3 kW	10.4 kW	17.0 kW	22.0 kW
Nominal voltage	635 VDC		630 VDC	
Operating voltage range	200–1000 VDC			
Standby power	40 W			
Night time power	< 2 W			
MPP tracker	Parallel inputs: 1 MPP tracker (DC1 and DC2 paralleled) Separate inputs: 2 MPP trackers (DC1 and DC2 connect to separate PV arrays)			
Maximum input voltage, open circuit	1000 VDC			
MPPT voltage range, full power	350–850 VDC		350–800 VDC	
DC connection type	MC4, 4 pairs (2 + 2)			
Maximum input current per MPPT	17 A	17 A	23 A	30 A
Maximum short circuit current per MPPT	24 A	24 A	30 A	30 A
AC output (grid side)				
Nominal output power	8 kVA	10 kVA	15 kVA	20 kVA
Nominal output voltage	230/400 VAC (3-phase + N + PE)			
Maximum current	12.8 A	16 A	24 A	32 A

Table A-2 Electrical specifications (Continued)

Parameter	Conext TL 8000 E	Conext TL 10000 E	Conext TL 15000 E	Conext TL 20000 E
Frequency range	47–63 Hz			
Total harmonic distortion	< 3% @ rated power			
Power factor	> 0.99 @ full power. Adjustable: 0.80 capacitive to 0.80 inductive			
DC current injection limit	0.5% rated output current Adjustment range: 0.01 to 1.0 A (default 0.7 A). Adjustment range for response time: 0.0 to 5.0 seconds (default 0.2 seconds).			
Peak efficiency	98.2%	98.3%	98%	
European	97.4%	97.7%	97.3%	97.5%
AC connector	5 wire, solderless; IP67			
Fuse	N/A. External over-current protection must be provided as part of installation.			
Acoustic noise level	<50 dBA at 1 meter		<55 dBA at 1 meter	
Cooling	Forced air cooling by one fan		Forced air cooling by four fans	

RCMU

Conext TL transformer-less inverters have an integrated electronic RCMU. This trips if the constant leakage current exceeds 300 mA, or suddenly occurring residual currents of 30 mA. The integrated RCMU is sensitive to both AC and DC leakage currents. For more information, refer to “RCMU Setting” on page 2–60.

NOTE: If an external RCD is used, it shall be a Type B RCD and trip current has to be at least 300 mA.

Maximum AC current during a voltage drop with LVRT function is limited as follow with the Conext TL:

- Conext TL 8000 E: 12.8 A
- Conext TL 10000 E: 16 A
- Conext TL 15000 E: 24A
- Conext TL 20000 E: 32 A

For AC external protection we recommend to use the breakers as given below.

- Conext TL 8000 E: 16 A
- Conext TL10000 E: 20 A
- Conext TL 15000 E: 24A
- Conext TL 20000 E: 32 A

System Information and Communication Specifications

Table A-3 System information and communication

Feature	Description
User interface	Black-on-white graphical LCD 365-day data logger and real-time clock 30 events record
Communication interface	Modbus (RS485)
Dry contact output connection	For remote indication of inverter status. Connected circuits must not exceed 28 VDC and 3 A.
RID (Remote Inverter Disable)	Two-terminal screw terminal block, for connection to dry (non-energized) switch or relay contacts. The contacts must be capable of switching 30 mA at 12 VDC.

Regulations and Directives

Table A-4 Regulations and directives

Feature	Conext TL 8000 E	Conext TL 10000 E	Conext TL 15000 E	Conext TL 20000 E
Electrical safety	CE marked for Low Voltage Directive according to EN/IEC 62109-1 / EN/IEC 62109-2		CE marked for the Low Voltage Directive according to EN/IEC 62109-1 / EN/IEC 62109-2 RCM marked for AS/NZS 3100	
Grid interconnection	VDE0126-1-1, VDE-AR-N 4105, RD1699, RD661, RD1663, CEI 0-21, UTE C15-712-1		BDEW, VDE0126-1-1, VDE-AR-N 4105, RD1663, RD661, ENEL-Guida, UTE C15-712-1, G59/2, AS4777.2, AS4777.3 CEI 0-21, Allegato A70 ^a , RD1699, P.O.12.3, IEC 62116, IEC 61727, MEA/PEA approval	
Environmental	RoHS, REACH			
EMC	CE marked for the EMC directive 2004-108-EC according to: <ul style="list-style-type: none"> • Emissions: EN 61000-6-3 (residential) • Immunity: EN 61000-6-2 (industrial) 			

a. LV grid – Chapter 5; MV grid – Chapter 5 and 8

Dimensions

See “Views and Dimensions” on page 2–17.

Efficiency Curves

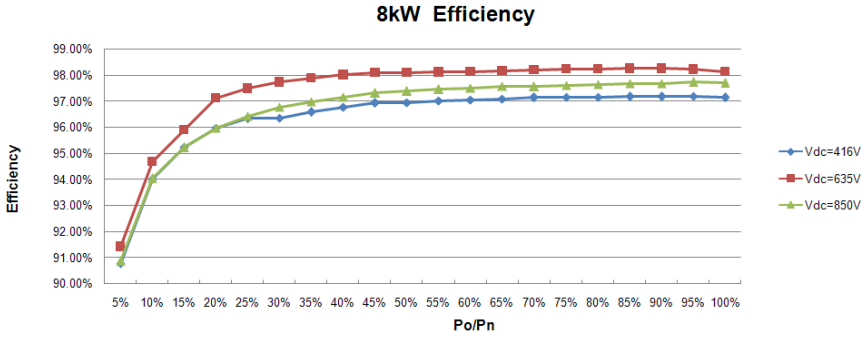

Figure A-1 Efficiency curves 8 kVA

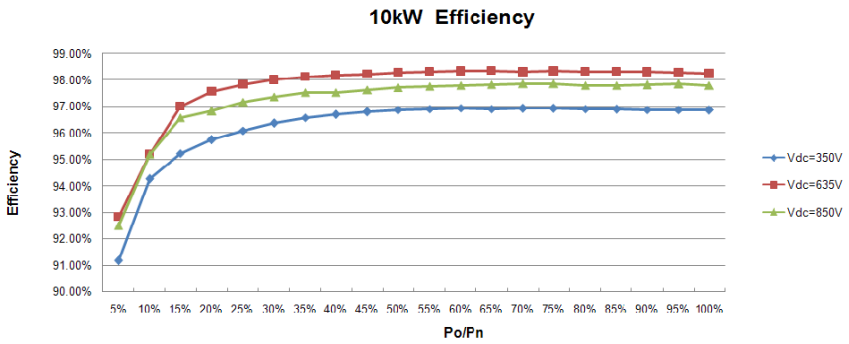

Figure A-2 Efficiency curves 10 kVA

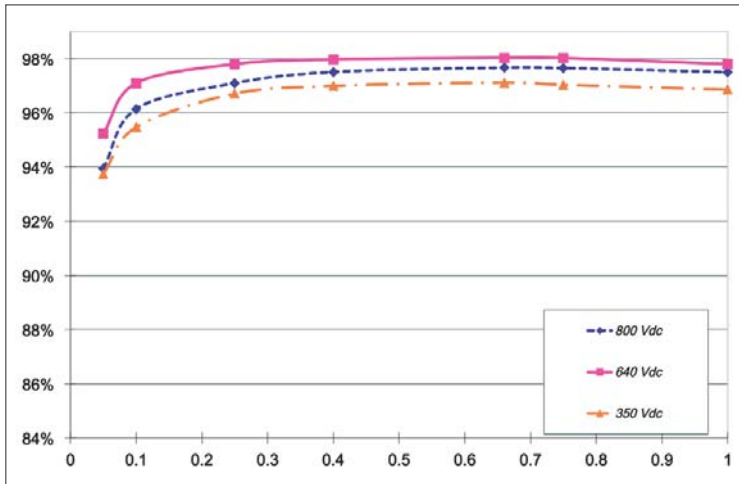

Figure A-3 Efficiency Curves 15 kVA

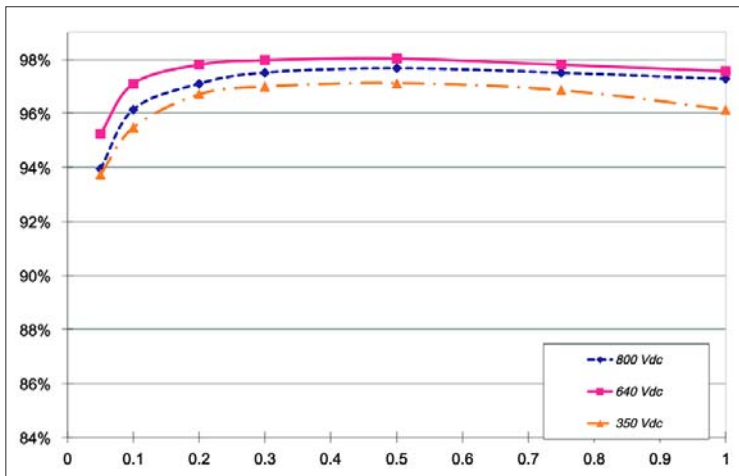

Figure A-4 Efficiency curves 20 kVA

B

Descriptions of LCD Information

Appendix B describes the information that can be displayed on the LCD of the inverter.

Description of Information Displayed on the LCD

Table B-1 describes text that is displayed on the LCD.

For a description of error messages, see Table 4-1 on page 4–2.

Table B-1 Text displayed on the LCD

LCD text	Description
Comm.-Version	Version of communication software
Day CO ₂ saved	Total CO ₂ emission prevented over the calendar day
DSP-Version	Firmware version
E-Day	Total electricity generated over the calendar day
E-Month	Total electricity generated over the calendar month
E-Today	Total energy generated today
E-Year	Total electricity generated over the calendar year
Fac High	The accumulated highest AC frequency (over the lifetime of the inverter)
Fac Low	The accumulated lowest AC frequency (over the lifetime of the inverter)
Heatsink-1, Max.	The accumulated highest temperature of heatsink-1 (over the lifetime of the inverter)
Heatsink-1, Min.	The accumulated lowest temperature of heatsink-1 (over the lifetime of the inverter)
Heatsink-2, Max.	The accumulated highest temperature of heatsink-2 (over the lifetime of the inverter)
Heatsink-2, Min.	The accumulated lowest temperature of heatsink-2 (over the lifetime of the inverter)
Heatsink-3, Max.	The accumulated highest temperature of heatsink-3 (over the lifetime of the inverter)
Heatsink-3, Min.	The accumulated lowest temperature of heatsink-3 (over the lifetime of the inverter)
Input 1 I	Current of MPP tracker 1

Table B-1 Text displayed on the LCD (Continued)

LCD text	Description
Input 1 I maximum	The accumulated highest MPP tracker 1 current (over the lifetime of the inverter)
Input 1 P	Power of MPP tracker 1
Input 1 P maximum	The accumulated highest MPP tracker 1 power (over the lifetime of the inverter)
Input 1 V	Voltage of MPP tracker 1
Input 1 Volt. maximum	The accumulated highest MPP tracker 1 voltage (over the lifetime of the inverter)
Input 2 I	Current of MPP tracker 2
Input 2 I maximum	The accumulated highest MPP tracker 2 current (over the lifetime of the inverter)
Input 2 P	Power of MPP tracker 2
Input 2 P maximum	The accumulated highest MPP tracker 2 power (over the lifetime of the inverter)
Input 2 V	Voltage of MPP tracker 2
Input 2 Volt. maximum	The accumulated highest MPP tracker 2 voltage (over the lifetime of the inverter)
Inside, Max.	The accumulated highest internal temperature of the inverter (over the lifetime of the inverter)
Inside, Min.	The accumulated lowest internal temperature of the inverter (over the lifetime of the inverter)
L1 I maximum	The accumulated highest AC L1 phase current (over the lifetime of the inverter)
L1 P maximum	The accumulated highest AC L1 phase power (over the lifetime of the inverter)
L1 Volt. maximum	The accumulated highest AC L1 phase voltage (over the lifetime of the inverter)
L2 I maximum	The accumulated highest AC L2 phase current (over the lifetime of the inverter)
L2 P maximum	The accumulated highest AC L2 phase power (over the lifetime of the inverter)

Table B-1 Text displayed on the LCD (Continued)

LCD text	Description
L2 Volt. maximum	The accumulated highest AC L2 phase voltage (over the lifetime of the inverter)
L3 I maximum	The accumulated highest AC L3 phase current (over the lifetime of the inverter)
L3 P maximum	The accumulated highest AC L3 phase power (over the lifetime of the inverter)
L3 Volt. maximum	The accumulated highest AC L3 phase voltage (over the lifetime of the inverter)
Life Energy	Total electricity generated (to present time)
Life Runtime	Total operation time
Month co2 saved	Total CO ₂ emission prevented in a month
Output I	Current of AC output
Output I maximum	The accumulated highest AC 3-phase current (over the lifetime of the inverter)
Output P	Power of AC output
Output P maximum	The accumulated highest AC 3-phase power (over the lifetime of the inverter)
Output V	Voltage of AC output
Output Volt. maximum	The accumulated highest AC 3-phase voltage (over the lifetime of the inverter)
Peak Day	The peak day of electricity generated in the past month
Peak Hour	The peak hour of electricity generated in the last 24 hours
Peak Month	The peak month of electricity generated in the past year
Power	Actual power harvested
Red.-Version	Redundant firmware version
Runtime	Total inverter operation time for today

Table B-1 Text displayed on the LCD (Continued)

LCD text	Description
Today CO ₂ saved	Total CO ₂ emission prevented today
Today Energy	Total electricity generated today
Today Runtime	Total operation time today
Total Power	Total real-time power (at that instant)
Uac High	The accumulated highest AC voltage (over the lifetime of the inverter)
Uac Low	The accumulated lowest AC voltage (over the lifetime of the inverter)
Year CO ₂ saved	Total CO ₂ emission prevented in a year

C

Country-Specific Settings

Appendix C describes the voltage and frequency disconnect settings and the reconnect time that the inverter provides for each country selectable from the user interface.

Description of Settings Specific to the Selected Country

The tables in this section list the voltage and frequency disconnect settings, and the reconnect time, that the inverter loads after you select a particular country in the Select Country screen (page 2–52).

Use Table C-1 to find the table that has your country settings.

Table C-1 Lookup table for country settings

Country	See this table:	On this page:
Australia	Table C-2	page C–3
Austria	Table C-3	page C–3
Belgium	Table C-4	page C–4
Czech	Table C-5	page C–5
Denmark	Table C-6	page C–6
England	Table C-7	page C–6
France	Table C-8	page C–7
Germany	Table C-9	page C–8
Greece	Table C-10	page C–9
Ireland	Table C-11	page C–10
Israel	Table C-12	page C–10
Italy	Table C-13	page C–11
Netherlands	Table C-14	page C–12
Portugal	Table C-15	page C–13
Spain	Table C-17	page C–14

Table C-2 Country-specific settings for Australia

Category	Item	Setting	Trip time (s)
Voltage Fast (VAC)	Vac High Off	270	2
	Vac High On	265	N/A
	Vac Low Off	200	2
	Vac Low On	205	N/A
Voltage Slow (VAC)	Vac High Off Slow	264.0	600
	Vac High On Slow	262.0	N/A
	Vac Low Off Slow	200	5
	Vac Low On Slow	205	N/A
Frequency Fast (Hz)	Fac High Off	55	2
	Fac High On	54.95	N/A
	F Low Off	45	2
	F Low On	45.05	N/A
Reconnect Time (s)		20	N/A

Table C-3 Country-specific settings for Austria

Category	Item	Setting	Trip time (s)
Voltage Fast (VAC)	Vac High Off	264.0	0.2
	Vac High On	259.0	N/A
	Vac Low Off	196.0	0.2
	Vac Low On	201.0	N/A

Table C-3 Country-specific settings for Austria (Continued)

Category	Item	Setting	Trip time (s)
Voltage Slow (VAC)	Vac High Off Slow	257.0	600
	Vac High On Slow	255.0	N/A
	Vac Low Off Slow	196.0	5
	Vac Low On Slow	201.0	N/A
Frequency Fast (Hz)	Fac High Off	51.00	0.2
	Fac High On	50.95	N/A
	F Low Off	49.7	0.2
	F Low On	49.75	N/A
Reconnect Time (s)		20	N/A

Table C-4 Country-specific settings for Belgium

Category	Item	Setting	Trip time (s)
Voltage Fast (VAC)	Vac High Off	253.0	0.1
	Vac High On	248.0	N/A
	Vac Low Off	207.0	0.1
	Vac Low On	212.0	N/A
Voltage Slow (VAC)	Vac High Off Slow	253.0	1.5
	Vac High On Slow	248.0	N/A
	Vac Low Off Slow	207.0	1.5
	Vac Low On Slow	212.0	N/A

Table C-4 Country-specific settings for Belgium (Continued)

Category	Item	Setting	Trip time (s)
Frequency Fast (Hz)	Fac High Off	50.5	0.1
	Fac High On	50.45	N/A
	F Low Off	47.5	0.1
	F Low On	45.55	N/A
Reconnect Time (s)		30	N/A

Table C-5 Country-specific settings for Czech

Category	Item	Setting	Trip time (s)
Voltage Fast (VAC)	Vac High Off	264	0.2
	Vac High On	259	N/A
	Vac Low Off	196	0.2
	Vac Low On	201	N/A
Voltage Slow (VAC)	Vac High Off Slow	264	5
	Vac High On Slow	259	N/A
	Vac Low Off Slow	196	5
	Vac Low On Slow	201	N/A
Frequency Fast (Hz)	Fac High Off	50.5	0.2
	Fac High On	50.45	N/A
	F Low Off	49.5	0.2
	F Low On	49.55	N/A
Reconnect Time (s)		180	N/A

Table C-6 Country-specific settings for Denmark

Category	Item	Setting	Trip time (s)
Voltage Fast (VAC)	Vac High Off	259.0	0.2
	Vac High On	254.0	N/A
	Vac Low Off	207	10
	Vac Low On	212	N/A
Voltage Slow (VAC)	Vac High Off Slow	253	40
	Vac High On Slow	251	N/A
	Vac Low Off Slow	207	5
	Vac Low On Slow	212	N/A
Frequency Fast (Hz)	Fac High Off	52.00	0.2
	Fac High On	51.95	N/A
	F Low Off	47.5	0.2
	F Low On	47.55	N/A
Reconnect Time (s)		20	N/A

Table C-7 Country-specific settings for England

Category	Item	Setting	Trip time (s)
Voltage Fast (VAC)	Vac High Off	276.0	0.5
	Vac High On	271.0	N/A
	Vac Low Off	192.0	0.5
	Vac Low On	197.0	N/A

Table C-7 Country-specific settings for England (Continued)

Category	Item	Setting	Trip time (s)
Voltage Slow (VAC)	Vac High Off Slow	264	1
	Vac High On Slow	259	N/A
	Vac Low Off Slow	208.0	2.5
	Vac Low On Slow	213.0	N/A
Frequency Fast (Hz)	Fac High Off	52.00	0.5
	Fac High On	51.95	N/A
	F Low Off	47	0.5
	F Low On	47.05	N/A
Frequency Slow (Hz)	Fac High Off	51.50	90.00
	Fac High On	51.45	N/A
	F Low Off	47.50	20.00
	F Low On	47.55	N/A
Reconnect Time (s)		180	N/A

Table C-8 Country-specific settings for France

Category	Item	Setting	Trip time (s)
Voltage Fast (VAC)	Vac High Off	264.0	0.2
	Vac High On	259.0	N/A
	Vac Low Off	184.0	0.2
	Vac Low On	189.0	N/A

Table C-8 Country-specific settings for France (Continued)

Category	Item	Setting	Trip time (s)
Voltage Slow (VAC)	Vac High Off Slow	253.0	600
	Vac High On Slow	251.0	N/A
	Vac Low Off Slow	184.0	5
	Vac Low On Slow	189.0	N/A
Frequency Fast (Hz)	Fac High Off	50.20	0.2
	Fac High On	50.15	N/A
	F Low Off	47.50	0.2
	F Low On	47.55	N/A
Reconnect Time (s)		30	N/A

Table C-9 Country-specific settings for Germany

Category	Item	Setting	Trip time (s)
Voltage Fast (VAC)	Vac High Off	264	0.2
	Vac High On	259	N/A
	Vac Low Off	184	0.2
	Vac Low On	189	N/A
Voltage Slow (VAC)	Vac High Off Slow	253	600
	Vac High On Slow	251	N/A
	Vac Low Off Slow	184	5
	Vac Low On Slow	189	N/A

Table C-9 Country-specific settings for Germany (Continued)

Category	Item	Setting	Trip time (s)
Frequency Fast (Hz)	Fac High Off	50.2	0.2
	Fac High On	50.15	N/A
	F Low Off	47.5	0.2
	F Low On	47.55	N/A
Reconnect Time (s)		30	N/A

Table C-10 Country-specific settings for Greece

Category	Item	Setting	Trip time (s)
Voltage Fast (VAC)	Vac High Off	264	0.5
	Vac High On	259	N/A
	Vac Low Off	184	0.5
	Vac Low On	189	N/A
Voltage Slow (VAC)	Vac High Off Slow	264	600
	Vac High On Slow	259	N/A
	Vac Low Off Slow	184	5
	Vac Low On Slow	189	N/A
Frequency Fast (Hz)	Fac High Off	50.5	0.5
	Fac High On	50.45	N/A
	F Low Off	49.5	0.5
	F Low On	49.55	N/A
Reconnect Time (s)		180	N/A

Table C-11 Country-specific settings for Ireland

Category	Item	Setting	Trip time (s)
Voltage Fast (VAC)	Vac High Off	253	0.5
	Vac High On	248	N/A
	Vac Low Off	207	0.5
	Vac Low On	212	N/A
Voltage Slow (VAC)	Vac High Off Slow	253	5
	Vac High On Slow	248	N/A
	Vac Low Off Slow	207	5
	Vac Low On Slow	212	N/A
Frequency Fast (Hz)	Fac High Off	50.5	0.5
	Fac High On	50.45	N/A
	F Low Off	48.00	0.5
	F Low On	48.05	N/A
Reconnect Time (s)		180	N/A

Table C-12 Country-specific settings for Israel

Category	Item	Setting	Trip time (s)
Voltage Fast (VAC)	Vac High Off	270.0	2
	Vac High On	265.0	N/A
	Vac Low Off	200.0	2
	Vac Low On	205.0	N/A

Table C-12 Country-specific settings for Israel (Continued)

Category	Item	Setting	Trip time (s)
Voltage Slow (VAC)	Vac High Off Slow	264.0	600
	Vac High On Slow	262.0	N/A
	Vac Low Off Slow	200	5
	Vac Low On Slow	205	N/A
Frequency Fast (Hz)	Fac High Off	55.00	2
	Fac High On	54.95	N/A
	F Low Off	45.00	2
	F Low On	45.05	N/A
Reconnect Time (s)		300	N/A

Table C-13 Country-specific settings for Italy

Category	Item	Setting	Trip time (s)
Voltage Fast (VAC)	Vac High Off	276.0	0.1
	Vac High On	271.0	N/A
	Vac Low Off	184.0	0.2
	Vac Low On	189.0	N/A
Voltage Slow (VAC)	Vac High Off Slow	276.0	5
	Vac High On Slow	271.0	N/A
	Vac Low Off Slow	184.0	5
	Vac Low On Slow	189.0	N/A

Table C-13 Country-specific settings for Italy (Continued)

Category	Item	Setting	Trip time (s)
Frequency Fast (Hz)	Fac High Off	50.3	0.1
	Fac High On	50.25	N/A
	Flow Off	49.7	0.1
	Flow On	49.75	N/A
Reconnect Time (s)		60	N/A

Table C-14 Country-specific settings for Netherlands

Category	Item	Setting	Trip time (s)
Voltage Fast (VAC)	Vac High Off	253.0	2
	Vac High On	249.0	N/A
	Vac Low Off	184.0	2
	Vac Low On	189.0	N/A
Voltage Slow (VAC)	Vac High Off Slow	253.0	5
	Vac High On Slow	249.0	N/A
	Vac Low Off Slow	184.0	5
	Vac Low On Slow	189.0	N/A
Frequency Fast (Hz)	Fac High Off	51.00	2
	Fac High On	50.95	N/A
	F Low Off	48.00	2
	F Low On	48.05	N/A
Reconnect Time (s)		180	N/A

Table C-15 Country-specific settings for Portugal

Category	Item	Setting	Trip time (s)
Voltage Fast (VAC)	Vac High Off	264	0.2
	Vac High On	259	N/A
	Vac Low Off	196	1.5
	Vac Low On	201	N/A
Voltage Slow (VAC)	Vac High Off Slow	264	5
	Vac High On Slow	259	N/A
	Vac Low Off Slow	196	5
	Vac Low On Slow	201	N/A
Frequency Fast (Hz)	Fac High Off	51	0.5
	Fac High On	50.95	N/A
	F Low Off	47	0.5
	F Low On	47.05	N/A
Reconnect Time (s)		180	N/A

Table C-16 Country-specific settings for Spain

Category	Item	Setting	Trip time (s)
Voltage Fast (VAC)	Vac High Off	253.0	0.2
	Vac High On	248.0	N/A
	Vac Low Off	196.0	0.2
	Vac Low On	201.0	N/A

Table C-16 Country-specific settings for Spain (Continued)

Category	Item	Setting	Trip time (s)
Voltage Slow (VAC)	Vac High Off Slow	253.0	5
	Vac High On Slow	248.0	N/A
	Vac Low Off Slow	196.0	5
	Vac Low On Slow	201.0	N/A
Frequency Fast (Hz)	Fac High Off	51.00	0.2
	Fac High On	50.95	N/A
	F Low Off	48.00	0.2
	F Low On	48.05	N/A
Reconnect Time (s)		180	N/A

Table C-17 Country-specific settings for Spain - RD1699

Category	Item	Setting	Trip time (s)
Voltage Fast	Vac High Off	264.0	0.2
Voltage Slow (VAC)	Vac High Off	253.0	1.5
	Vac Low Off	196	1.5
Frequency Fast (Hz)	Fac High Off	≥ 50.5 Hz	0.5
	Fac Low Off	≤ 48 Hz	3

Table C-18 Country-specific settings for Thailand

Category	Item	Setting	Trip time (s)
Voltage Fast (VAC)	Vac High Off	311.0	0.05
	Vac High On	N/A	N/A
	Vac Low Off	114.0	0.1
	Vac Low On	N/A	N/A
Voltage Slow (VAC)	Vac High Off Slow	241.0	2s
	Vac High On Slow	N/A	N/A
	Vac Low Off Slow	199.0	2s
	Vac Low On Slow	N/A	N/A
Frequency Fast (Hz)	Fac High Off	≥ 51.0	0.1
	Fac High On	N/A	N/A
	F Low Off	≤ 49.0	0.1
	F Low On	N/A	N/A
Reconnect Time (s)		>120s	N/A

Information About Your System

As soon as you open your Conext TL series photovoltaic grid tie inverter package, record the following information and be sure to keep your proof of purchase.

- Serial Number _____
- Part Number _____
- Purchased From _____
- Purchase Date _____

Index

Numerics

2004-108-EC (EMC directive) A-6

A

abbreviations v

AC

- cable, maximum length 2-30
- cable, preparing and connecting 2-9 to 2-35
- connector (specifications) A-4
- grid connection 2-9, 2-29
- output, viewing values 3-6
- plug 2-29
- specifications A-3

AC Current High (LCD message) 4-4

AC Freq High (LCD message) 4-6

AC Freq Low (LCD message) 4-6

AC Over Current (LCD message) 4-4

AC Switch Response (LCD message) 4-2

AC Volt High (LCD message) 4-6

AC Volt Low (LCD message) 4-6

acronyms v

active power control

- setting 2-62 to 2-65

Active/Reactive Power menu 2-62

air outlets

- cleaning 5-7
- location 2-19

airflow 2-19, 2-20

ambient environment 2-10

Analog Input Bias (LCD message) 4-3

AS/NZS 3100 A-6

AS4777.2 A-6

AS4777.3 A-6

audience of this document iii

B

bottom view of inverter 2-17, 2-18

brightness, LCD 3-9

Bus Unbalance (LCD message) 4-5

buttons, description 2-51, 3-3

C

caution

- definition iv
- heavy object 2-12

risk of equipment damage 2-3, 2-5, 2-11, 2-12, 2-13, 2-30, 2-31, 2-36, 2-37, 2-43, 2-45, 2-49, 5-8

CE A-6

cleaning

- air outlets 5-7
- fans 5-3

clearance required 2-11

CO2 Saved 2-57

Coefficient Settings menu 2-57

color coding (phase sequence) 2-29

Comm.-Version 3-8

communication module

- cables, connecting 2-43
- description 2-41
- removing 2-42
- software version 3-8

communication software, version 3-8

communication specifications A-5

components, typical installation 1-2

conductor sizing, recommended

AC 2-9

DC 2-4

connection diagram (wiring) 2-6, 2-7

connectors, external

- location 1-8

Constant $\cos\phi$ 2-66

constant reactive power (Q) 2-69

contents of the package 2-12

contrast, LCD 3-9

control panel 3-2

conventions iv

$\cos\phi(P)$ 2-67

country, selecting 2-52

crimping tool 2-4, 2-37

Current Sensor (LCD message) 4-2

D

danger

definition iv

hazard of electric shock 2-2, 2-20, 2-29, 2-34, 2-42, 5-2

hazard of fire, arc flash, or electric shock ix

date format, setting 3-9

date, setting 2-57, 3-9

Day CO2 saved B-2

DC

- current injection (AC output) A-4
- input, viewing values 3-6

maximum operating current 2-4, A-3
requirements 2-3
specifications A-3
wiring 2-37

DC Injection
LCD message 4-5
setting 2-60

DC Overcurrent (LCD message) 4-5

DC wiring polarity 2-37

default settings, restore 2-77

definitions v

deleting logs 2-77

dictionary (glossary) v

dimensions
inverter 2-17, 2-18
mounting plate 2-23

direct sunlight 2-11

directives A-6

Down button 2-51, 3-3

dry contact
input connection 2-49
output connection 2-50

DSP-Version 3-8

E

earthing terminal 1-8, 2-38

E-Day B-2

electrical specifications 2-4, A-3

EMC directive 2004-108-EC A-6

E-Month B-2

EN 61000-6-3 A-6

enclosure (specifications) A-2

ENEL-Guida A-6

Energy Log 3-7

environmental specifications 2-42, A-2

error codes 4-2

error messages 4-2

ESC button 2-51, 3-3

E-Today
field description B-2
screen 3-4

Event Log 3-8

exiting the technician or service mode level
of security access 2-77

external DC disconnect switches 2-8

external over-current protection A-4

E-Year B-2

F

Fac High B-2

Fac Low B-2

Fan Rotation (LCD message) 4-7

fans, cleaning 5-3

fault ride through (FRT)
setting 2-72

features of inverter

list 1-2
locations 1-5, 1-6

firmware version 3-8

fixed power factor (Constant cos ϕ) 2-66

flashing light (LED) 3-4

frequency range (AC output) A-4

frequency, viewing values 3-6

frequency-dependent active power control
setting 2-63

FRT (fault ride through)
setting 2-72

fuse A-4

G

G59/2 A-6

galvanic isolation A-2

glossary v

grid
AC connection 2-9, 2-29
connection type 2-61
Grid Quality (LCD message) 4-7
Grid Setting 2-62
Grid System setting 2-61
interconnection regulatory approvals A-6

Grid Quality (LCD message) 4-7

Grid Setting 2-62

Grid System setting 2-61

Ground Current High (LCD message) 4-5

H

harmonic distortion, total A-4

hazard of electric shock 2-2, 2-3, 2-20, 2-29, 2-33, 2-34, 2-37, 2-38, 2-39, 2-41, 2-42, 2-49, 2-52, 5-2

hazard of electric shock and fire 2-4, 2-36, 2-37, 2-58, 2-60, 2-61

hazard of electric shock, fire, and equipment damage x, 2-2

hazard of fire 2-10, 2-35, 2-59

hazard of fire, arc flash, or electric shock ix

hazard of shock 2-50

Heatsink-x, Max. B-2

Heatsink-x, Min. B-2

heavy object (caution) 2-12

home page (E-Today) 3-4

humidity, relative A-2

HW COMM1 (LCD message) 4-4

HW COMM2 (LCD message) 4-2

HW Connect Fail (LCD message) 4-5

HW Efficiency (LCD message) 4-4

HW ZC Fail (LCD message) 4-4

I

ID of inverter
setting 2-58

viewing 3–8
 IEC 61730 Class A rating 2–3
 IEC 62109-1 A–6
 IEC 62109-2 A–6
 important physical features of inverter 1–5, 1–6
 indicator light (LED) 3–4
 "Information about Your System" form D–1
 Input 1 I B–2
 Input 1 I maximum B–3
 Input 1 P B–3
 Input 1 P maximum B–3
 Input 1 V B–3
 Input 1 Volt. maximum B–3
 Input 2 I B–3
 Input 2 I maximum B–3
 Input 2 P B–3
 Input 2 P maximum B–3
 Input 2 V B–3
 Input 2 Volt. maximum B–3
 Inside, Max. B–3
 Inside, Min. B–3
 Install Settings menu 2–58
 installation
 overview 2–2
 date, viewing 3–8
 PV planning 2–3
 tools required 2–16
 typical (drawing) 1–2
 See also mounting
 insulation detection method 2–59
 interface panel 1–8
 inverter
 earthing terminal 2–38
 ID, setting 2–58
 ID, viewing 3–8
 installation 2–2
 mounting onto wall 2–20
 purchase date D–1
 serial number D–1
 turning on/off 3–2
 Inverter Information screen 3–8
 Isolation Impedance Error (LCD message) 4–7
 isolation, galvanic A–2
 Italy Selftest 2–76

L

L1 I maximum B–3
 L1 P maximum B–3
 L1 Volt. maximum B–3
 L2 I maximum B–3
 L2 P maximum B–3
 L2 Volt. maximum B–4
 L3 I maximum B–4
 L3 P maximum B–4
 L3 Volt. maximum B–4
 label of inverter, location 2–14

label, safety 1–6
 language, setting 2–54, 3–6
 LCD
 brightness 3–9
 contrast 3–9
 field labels displayed B–2
 location 1–5, 1–6
 messages displayed 4–2
 LED (indicator light) 3–4
 Life Energy B–4
 Life Runtime B–4
 light indicator (LED) 3–4
 limitations on use ix
 location of installation 2–2
 logs
 deleting 2–77
 event log 3–8
 power generation logs 3–7
 Low Voltage Directive A–6
 Low Voltage Ride Through (LVRT)
 setting 2–72
 LVD grid connection type 2–61
 LVRT (Low Voltage Ride Through)
 setting 2–72

M

main menu
 accessing 3–5
 screenshot 2–54, 3–5
 structure of menu tree (no password entered) 3–5
 structure of menu tree (password entered) 2–55, 2–56
 maintenance, periodic 5–2
 maximum AC output, viewing 3–7
 maximum current (AC output) A–3
 maximum DC input, viewing 3–7
 maximum operating current, DC 2–4, A–3
 menu
 Personal Settings 3–9
 Settings menu 3–9
 structure (no password entered) 3–5
 structure (password entered) 2–55, 2–56
 See also main menu
 messages (LCD) 4–2
 Month co2 saved B–4
 mounting
 correct position 2–20
 incorrect positions 2–21
 inverter 2–20
 location, choosing 2–20
 See also mounting plate
 mounting plate
 correct position 2–23
 dimensions 2–23
 fastening to wall 2–25
 MPP tracker 2–6, A–3
 Multi-Contact 2–38

multiple inverters

- RS485 wiring 2-45
 - termination resistor 2-48
- MVD grid connection type 2-61

N

- night time power A-3
- No Alarm (LCD message) 4-2
- No Grid (LCD message) 4-7
- noise level A-4
- nominal power (AC output) A-3
- nominal voltage (AC output) A-3
- nominal voltage (DC input) A-3

O

- off-grid function (not supported) ix
- OK button 2-51, 3-3
- operating current, maximum, DC 2-4, A-3
- operating temperature A-2
- operating voltage A-3
- operation 3-1 to 3-9
- Operation Data screen 3-7
- Output I B-4
- Output I maximum B-4
- Output P B-4
- Output P maximum B-4
- Output V B-4
- Output Volt. maximum B-4
- over-current protection, external A-4
- overvoltage category A-2
- Overvoltage DC (LCD message) 4-5

P

- package contents 2-12
- packing list 2-12
- panel, interface 1-8
- password 2-58
- Peak Day B-4
- Peak Hour B-4
- Peak Month B-4
- performance values, viewing 3-6
- periodic maintenance 5-2
- Personal Settings menu 3-9
- phase sequence
 - color coding 2-29
- physical features of inverter 1-5, 1-6
- planning of installation 2-2
- plug, AC 2-29
- polarity, wiring, DC 2-37
- Power (LCD text) B-4
- power control
 - active. See active power control.
 - reactive. See reactive power control.
- power factor (AC output) A-4
- power factor as a function of active power

- ($\cos\phi(P)$) 2-67
- power generation logs, viewing 3-7
- power limit, setting 2-63
- Power Meter screens 3-6
- power, night time A-3
- power, standby (DC input) A-3
- pressure washer, caution 2-11
- proof of purchase D-1
- protection
 - degree A-2
 - external over-current A-4
- protective devices, recommended
 - AC 2-9
 - DC 2-4
- purchase date D-1
- PV
 - DC wiring 2-37
 - earthing terminal 1-8, 2-38
 - external DC disconnect switches 2-8
 - only ungrounded conductors are supported 2-37
 - planning 2-2
 - requirements 2-3
 - short circuit current limit (warning) 2-2
 - sizing tool 2-3
- PV OC Voltage Low (LCD message) 4-7
- PV Voltage High (LCD message) 4-7

Q

- Q(U) 2-70

R

- RCD 3-vi
- RCM marked A-6
- RCMU (Residual Current Monitoring Unit) 2-60
- RCMU Fault (LCD message) 4-4
- RD1663 A-6
- RD661 A-6
- reactive power control
 - overview 2-66
 - constant reactive power (Q) 2-69
 - fixed power factor (Constant $\cos\phi$) 2-66
 - power factor as a function of active power ($\cos\phi(P)$) 2-67
 - Q(U) 2-70
- recommended conductor sizing
 - AC 2-9
 - DC 2-4
- recommended protective devices
 - AC 2-9
 - DC 2-4
- Red.-Version 3-8, B-4
- redundant firmware version 3-8
- regular maintenance 5-2
- regulations A-6

relative humidity A-2
 Relay Test O/C (LCD message) 4-4
 Relay Test S/C (LCD message) 4-4
 requirements
 DC 2-3
 environmental 2-10
 Residual Current Monitoring Unit (RCMU)
 2-60
 Return to Factory (restore default settings)
 2-77
 RID (Remote Inverter Disable) 2-49
 risk of equipment damage 2-3, 2-5, 2-11,
 2-12, 2-13, 2-30, 2-31, 2-36, 2-37, 2-
 43, 2-45, 2-49, 2-50, 5-8
 RJ-45 connectors 2-46
 RoHS A-6
 RS485 connection
 overview 2-45
 data format 2-46
 through 5-position terminal block 2-47
 through RJ-45 connectors 2-46
 Runtime B-4

S

safety
 important safety instructions ix
 label 1-6
 switches, external DC disconnect 2-8
 See also caution, danger, warning.
 safety class A-2
 Schneider Electric
 web site vi
 scope of this document iii
 screen saver 3-9
 screwdrivers required 2-16
 Select Country screen 2-52
 Select Language screen 2-54
 Selftest, Italy 2-76
 semi-annual maintenance 5-3
 serial number
 place to write down D-1
 viewing 3-8
 service mode password 2-58
 Settings menu
 no password entered 3-9
 password entered 2-57
 side view of inverter 2-17, 2-18
 sizing tool, PV 2-3
 solar cells. See PV
 specifications
 AC output A-3
 communication A-5
 DC input A-3
 electrical 2-4, A-3
 environmental 2-42, A-2
 system A-2
 spray, caution 2-11
 sprinklers, caution 2-11

stand-alone function (not supported) ix
 standby power (DC input) A-3
 sunlight, direct 2-11
 system information A-5
 system specifications A-2

T

technician password 2-58
 temperature
 inside the inverter, viewing 3-7
 operating A-2
 terminal block, 5-position 2-47
 termination resistor 2-48
 terms (definitions) v
 text displayed on LCD B-2
 Thermal Condition (LTP) (LCD message) 4-
 2
 Thermal Condition (OTP) (LCD message)
 4-2
 Thermal Sensor 1 (LCD message) 4-2
 Thermal Sensor 2 (LCD message) 4-2
 Thermal Sensor 3 (LCD message) 4-3
 Thermal Sensor 4 (LCD message) 4-3
 time, setting 2-57, 3-9
 Today CO2 saved B-5
 Today Energy B-5
 Today Runtime B-5
 tools required for installation 2-16
 top view of inverter 2-17, 2-18
 total harmonic distortion A-4
 Total Power B-5
 total power, viewing values 3-6
 turning inverter on/off 3-2
 typical installation 1-2

U

Uac High B-5
 Uac Low B-5
 unpacking 2-12
 Up button 2-51, 3-3
 UTE C15-712-1 A-6

V

VDE0126-1-1 A-6
 VDE0126-1-1 grid connection type 2-61
 VDE-AR-N 4105 A-6
 ventilation 2-11
 version information 3-8
 views of the inverter 2-17, 2-18

W

wall, fastening mounting plate to 2-25
 warning
 definition iv

Index

- hazard of electric shock 2-3, 2-33, 2-37, 2-38, 2-39, 2-41, 2-49, 2-52
- hazard of electric shock and fire 2-4, 2-36, 2-37, 2-58, 2-60, 2-61
- hazard of electric shock, fire, and equipment damage x, 2-2
- hazard of fire 2-10, 2-35, 2-59
- hazard of shock 2-50
- limitations on use ix
- risk of equipment damage 2-50
- web site, Schneider Electric vi
- weight A-2
- wiring
 - AC 2-9, 2-29
 - connection diagram 2-6, 2-7
 - DC 2-37
- wiring polarity, DC 2-37

Y

- Year CO2 saved B-5

Schneider Electric

www.schneider-electric.com

Please contact your local Schneider Electric Sales Representative or visit our website at:
<http://www.schneider-electric.com/sites/corporate/en/support/operations/local-operations/local-operations.page>